

# A Revisit and Review of Experimental Variables Affecting Chromatographic Organics – Polydimethylsiloxane Interactions

Edison Muzenda

**Abstract**—The effect of experimental variables namely liquid loading, sample size, temperature, vapour pressure and carrier gas flow rate on volatile organic compounds (VOCs) specific retention volumes was studied using the gas – liquid chromatographic technique (GLC) with polydimethylsiloxane (PDMS) as the stationary phase. All VOCs were found to exhibit negative deviation from Raoult's law. This was achieved through studying the effect of

sample size on  $V_g$ , plotting  $\log V_g$  against  $\log P^o$ , qualitatively analyzing peak asymmetry and calculating mole fraction based activity coefficients. Absorption was found to be the main sorption mechanism through working with columns with different liquid loading. Measurements were highly reproducible with the relative standard deviation and coefficient of variation in the measurement of specific retention volumes of  $1.3 \times 10^{-4}$  and 0.013 respectively. Uniformly symmetrical elution peaks obtained by injecting very small volumes of solutes confirm that the criterion for infinite dilution approximation was met. Prerequisites for the application of the GLC to polymer solution thermodynamics are also presented. Knowledge of VOCs interaction with polymeric solvents is required in the design of absorbers and strippers for the abatement of volatile organic compounds.

**Keywords**—Absorption, liquid loading, polymers, sorption mechanism, specific retention volume, thermodynamics

## I. THEORY

### A. Liquid Loading

High polymers lie somewhere between conventional crystalline solids and ordinary liquids with respect to viscosity and diffusivity of small molecules in the polymer phase, therefore there are two mechanisms for solute sorption namely (i) absorption of solutes in the bulk polymer phase (ii) adsorption of solutes in the polymer surface. A quantitative treatment of the data is best carried out when absorption is the dominant mechanism. When the solute is held back by absorption only, the retention volume is directly proportional to the amount of liquid loading (amount of polymer in the

column). In the case of adsorption, a proportional relationship exists between the retention volume and polymer surface area. The surface area is not generally proportional to the weight of the polymer. Therefore by using columns with different loading, it is possible to investigate if absorption is the dominant mechanism. In the presence of a direct proportionality exists between retention volume and liquid loading, adsorption on the column wall and non covered parts of solid support surface can be ruled out [1].

### B. Temperature

The dependence of retention in particular specific retention volumes, Kovats indices and partition coefficients on temperature has been studied and the relationship is frequently linear [2]-[10]. This can be related to the thermodynamics of the systems. For vapor – liquid equilibrium, Dalton and Henry's laws give (1)

$$y_1 = \gamma_1 x_i P_i^o \quad (1)$$

The effect of temperature on vapour pressure, activity coefficients and specific retention volume is given by (2), (3) and (4) respectively

$$\ln P^o \alpha - \frac{\Delta H_e}{RT} \quad (2)$$

$$\ln \gamma \alpha - \frac{\Delta H_d}{RT + 1} \quad (3)$$

$$\log V_g = \frac{\Delta H}{2.3RT + K_2} \quad (4)$$

$K_1$ ,  $K_2$  are constants and plots of  $\log K/T$  or  $\log V_g$  against  $1/T$  are linear if  $\Delta H$  is constant.

### C. Vapour Pressure

When the accuracy within which retention data are normally determined and the short temperature range of most practical interest in gas chromatography are taken into account, the assumption of constant  $\Delta H$  is frequently justified. Therefore equations (2) and (4) can be combined to give equation (5).

Edison Muzenda is with the Department of Chemical Engineering, University of Johannesburg, Doornfontein, Johannesburg, South Africa, 2028 (tel: 0027115596817; fax: 002711596430; email: emuzenda@uj.ac.za)

$$\log V_g = K_3 - \left( \frac{\Delta H}{\Delta H_e} \right) \log P^o \quad (5)$$

When values of  $P^o$  and  $V_g$  are obtained at the same temperature, Plots of  $\log V_g$  against  $\log P^o$  are therefore linear with slope of  $-\left(\frac{\Delta H}{\Delta H_e}\right)$ . For ideal solutions  $\Delta H_d = 0$ , and  $\Delta H = \Delta H_e$ , and the slope is -1. Slopes other than -1 are a measure of departure from ideal behaviour.

#### D. Sample Size

The term sample size is usually taken to refer to the total amount of solute injected whether measured in moles,  $\mu\text{l}$ , mg or other units. If exact retention volumes are desired, their variation with sample size must be found by measuring the peak positions of several small sized samples. This allows extrapolation to the position of a vanishingly small sample (infinite dilution). Calculations of sample size at which several concentrations dependent effects become significant concluded that for finite dilution studies, samples should be limited to about 0.1mg (0.1  $\mu\text{l}$ ) liquid in GLC. It is recommended to attempt a few runs with smaller samples to assess if retention time or plate height remains constant. An investigation of the influence of sample size on retention is usually advisable. Unexpected observations such as maxima and minima in plots of retention volume against sample size may mean that adsorption or reaction effects are present in addition to the retention mechanism under study. When reporting retention data, it is important to indicate the sample size. Very little confidence may be placed on the data without sample information.

#### E. Carrier Gas Flow Rate

Flow rate was found to have no significant influence on retention [11]-[13]. This is because the retention time is inversely proportional to the flow rate, hence if the mobile phase flow rate is doubled the retention time,  $t_R$  will be halved.

## II. MATERIALS AND METHOD

### A. Experimental Requirements.

For accurate physio-chemical measurements, ordinary chromatographic apparatus must be modified to some extent. Refinements of analytical chromatographs should be done mainly in the control and measurement of column temperature, effluent flow rate as well as inlet and outlet pressures. Temperature must be known and controllable to better than  $\pm 0.05$ . In physiochemical measurements it is required to know accurately ( $\pm 2\%$ ) the weight of the

stationary phase in the column to within ( $\pm 2\%$ ) accuracy [14]. Retention parameters of all solutes and that of non retained substance for example the air peak should be accurately measurable and reproducible. Retention volumes must be related only to the solute – bulk liquid stationary phase interactions. The instrumental requirements for this technique are fairly straight forward.

### B. Typical Gas Chromatography

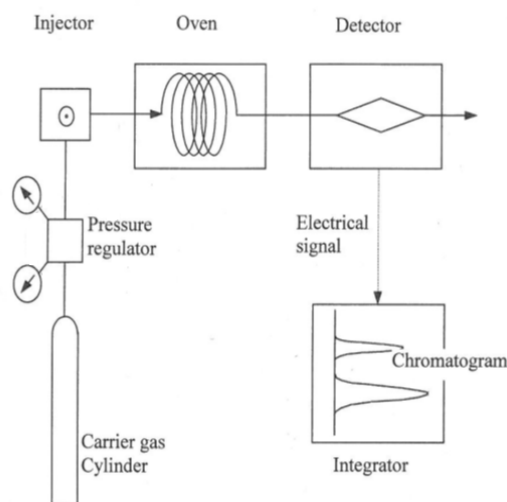

Fig. 1 Typical gas chromatographic set up

The essential parts are:

- Carrier gas supply at constant pressure. This is obtained from a commercial cylinder fitted with a pressure reducing valve, followed by a drying tube.
- Needle valve or precise pressure regulator for fine adjustment of flow rate
- Manometer or pressure gauges
- Sample introduction system
- Chromatographic column
- Thermostat
- Detector, the output of which is normally fitted to the recorder
- Flow meters

Apparatus effectiveness depends on the attention paid to the preparation of the column and the introduction of the sample. The sample must be vaporised rapidly so that equilibrium between the two phases occurs as quickly as possible, this is frequently achieved by provision of a special flasher heater at the point of injection. Temperatures should not be too high to decompose the sample.

The liquid used as the stationary phase must satisfy the following requirements as far as possible (i) low volatility (ii) low viscosity (iii) thermal stability (iv) Chemical inertness except when some chemical interactions are used to achieve separation. Polydimethylsiloxane satisfies all these conditions very well.

### C. Stationary Phase and Column Description

Three PDMS polymers were used as stationary phases in this work. The polymers differed in their average molecular weight, which ranged from 760 to 13 000. In columns 1 to IV, PDMS were coated into Chromosorb P support (60 – 80 mesh, acid washed and dimethylchlorosilane treated) from a solution in chloroform. The solvent was then evaporated in a shaker water bath. The solution was continuously stirred during the evaporation period to allow the solid support to be in contact with the PDMS. Drying the coated particles to constant weight was achieved through heating on magnetic stirrer at a temperature of 120°C. The amount of polymer on the support was found through weighing. The coated supports were packed into 1m length, 6.35mm o.d. stainless steel columns that were previously washed with in methanol. Glass wool was pushed through them. Table 1 shows the details of these columns. Column 4 was prepared and supplied by Perkin Elmer according to our study requirements.

TABLE I  
COLUMN DESCRIPTION

Code	I	II	III	IV	V
length, m	1	1	1	1	1
Chromosorb W or P. g	6.158	7.186	7.2	6.914	4.86
Weight of PDMS	0.688	0.804	1.8	2.97	0.54
% Loading	10.05	10.06	20	30.05	10
Viscosity of PDMS, cs	5	50	50	50	500
Mwt of PDMS	760	3200	3200	3200	13000

### D. Solutes

Thirteen solutes namely chloroform, pentane, hexane, heptane, acetone, toluene, cyclohexane, xylene, diethylether, butyl acetate, isobutyl methyl ketone, triethyl amine and ethyl methyl ketone, purchased from either Merck Ltd were used for chromatographic work as received. The purity of these compounds was above 99%.

### E. Procedure

A Perkin Elmer Gas Chromatograph 8500 model equipped with flow meter, pressure gauge, thermal conductivity and flame ionization detectors was used. Temperature control was obtained by means of circulating air oven. Temperature was varied from 303.15K to 333.15K. In this temperature range the stationary phase (PDMS) vapour pressure was negligible. The use of helium as a carrier gas minimized solution effects in the solvent [15].

Flow rates in the range of 20 – 50 ml/ min were measured at room temperature using a soap bubble flow meter at the detector outlet. This was done to study the influence of flow rate on the retention volume. An Altech, inlet pressure gauge was used to measure inlet pressures in the range of 900 to 11000mmHg and the outlet pressure was always considered as atmospheric [16]. Various sample sizes ranging from 0.1  $\mu\text{l}$  to 10  $\mu\text{l}$  were injected using either a 1 or 10  $\mu\text{l}$  Hamilton

syringe. The gas holdup was correctly accounted for by taking the retention as the difference between the position of the maxima of the air and the solute peaks.

## III. RESULTS AND DISCUSSION

### A. Liquid Loading

The effect of liquid loading on retention volume was studied using three columns with 10%, 20% and 30% liquid loading. Six VOCs namely, pentane, hexane, heptane, diethylether, acetone and chloroform were used to study this variable. The influence of liquid loading on retention volume is shown in Figs. 2 and 3. A direct proportionality exists between retention volume and liquid loading. This strongly indicates that the solutes (VOCs) were held back exclusively by absorption in the bulk of the polymer phase. Thus, the theory of gas liquid partition chromatography can be applied to the retention data to calculate various thermodynamic quantities.

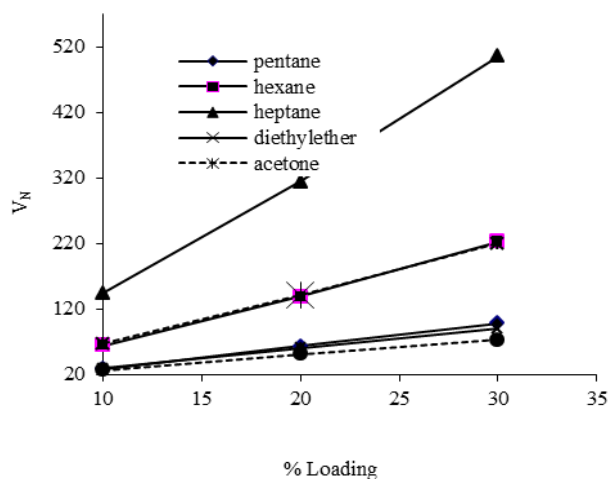

Fig. 2 Effect of liquid loading on net retention volume ( $V_N$ )

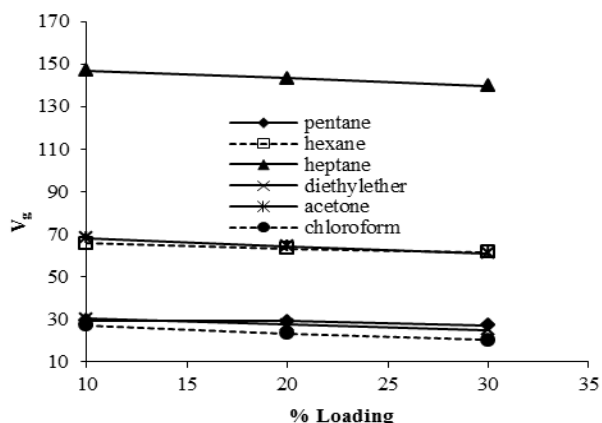

Fig. 3 Effect of liquid loading on specific retention volume ( $V_g$ )

### B. Sample Size

The retention volumes of pentane, acetone, chloroform, diethyl ether and ethyl methyl ketone were measured at a constant flow rate of 40.01 ml/min, column temperature of 333K with sample sizes varied from 0.1 to 10  $\mu\text{l}$  in column IV. Figs. 4 and 5 show the variation of retention volume with sample size. A trend towards earlier peak elution was observed with increasing sample size. The peaks broadened and become more unsymmetrical as sample size is increased from 0.1 to 10  $\mu\text{l}$ . In all cases the retention volume decreases with increasing sample size. This corresponds to an increase in  $\gamma$  [1] and this shows negative deviation from ideal behaviour. Inspecting the symmetry of the peaks also gave qualitative information on deviations [17]. All the compounds gave sharp leading and diffuse tailing peaks. This is in accordance with the deviations from Raoult's law as predicted from chromatographic theory. Also uniformly symmetrical peaks obtained by injecting small samples can be considered to confirm the infinite dilution approximation [14] thus representing solute – solvent equilibrium interactions. Keeping with Conder's admonition [18] peak asymmetry does not necessarily indicate surface adsorption effects as this could also be due to poor sample introduction and huge sample size as was in some cases in this work.

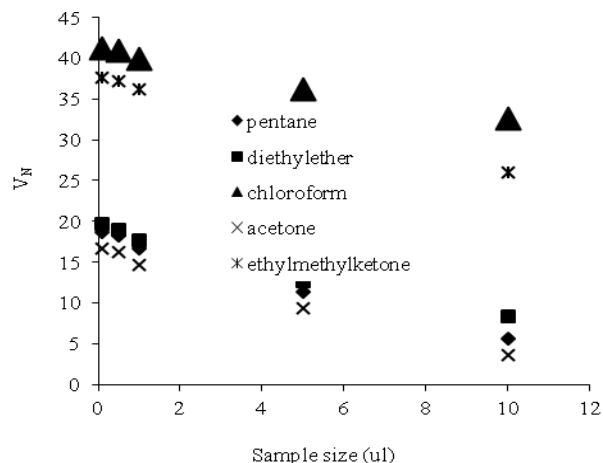

Fig. 4 Effect of sample size on net retention volumes (500PDMS-column 4)

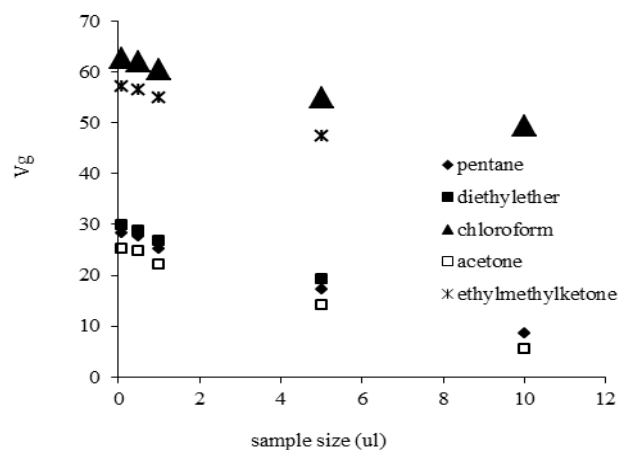

Fig. 5 Effect of sample size on specific retention volumes (500PDMS- column 4)

### C. Temperature and Vapour Pressure

Specific retention volumes of chloroform (1), pentane (2), hexane (3), heptane (4), acetone (5), toluene (6), cyclohexane (7), xylene (8), diethylether (9), butylacetate (10), isobutylmethylketone (11), triethylamine (12) and ethylmethylketone (13) coded as numbered were measured by injecting a constant sample size of 0.1  $\mu\text{l}$  into column 4. Temperature was varied from 303K to 333K at a constant mean flow rate of 35.97 ml/min. The influence of temperature on specific retention volumes is shown in Fig. 6 and detailed discussions were presented by [19]. Fig. 6 shows almost linear dependence of  $\log V_g$  on  $1/T$  with  $V_g$  decreasing with increasing temperature. Chromatographic retention data from variable temperature runs may be used to estimate thermodynamic properties according to the well known Van't Hoff relation [20].

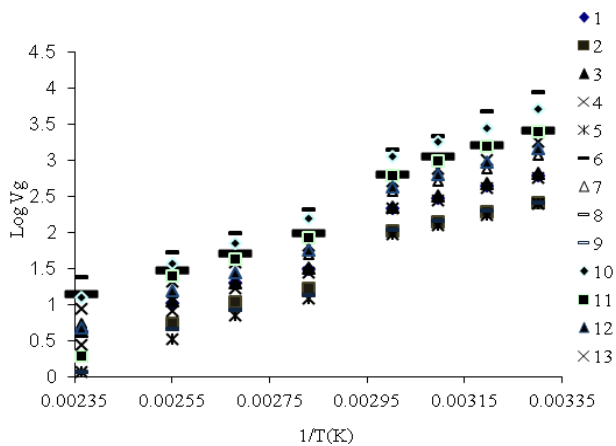

Fig. 6 Influence of temperature on specific retention volumes (Column 4)

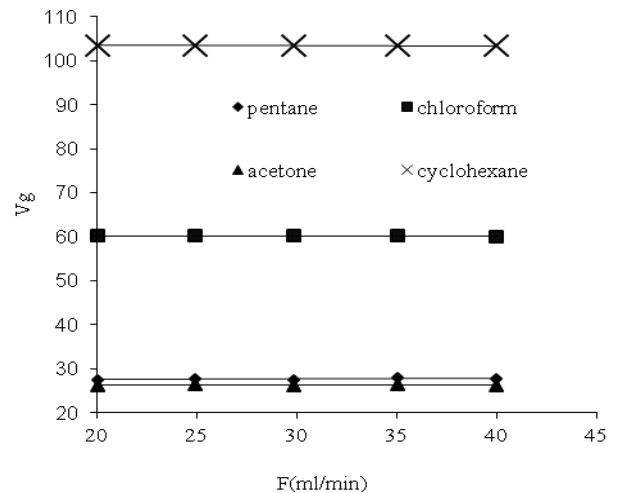

Fig. 8 Effect of carrier gas flow rate on specific retention volumes (500PDMS- column 4)

#### D.Flow Rate

The retention volumes of pentane, chloroform, acetone and cyclohexane at a constant sample size of  $0.1 \mu\text{l}$  were measured at varying flow rates ranging from 20.01 ml / min to 40.0ml / min at 333K in column V. As shown in Figs. 6 and 7, flow rate was found to have no influence on retention in this work. Thus increasing the flow rates up to 40ml / min did not upset the equilibrium in the column.

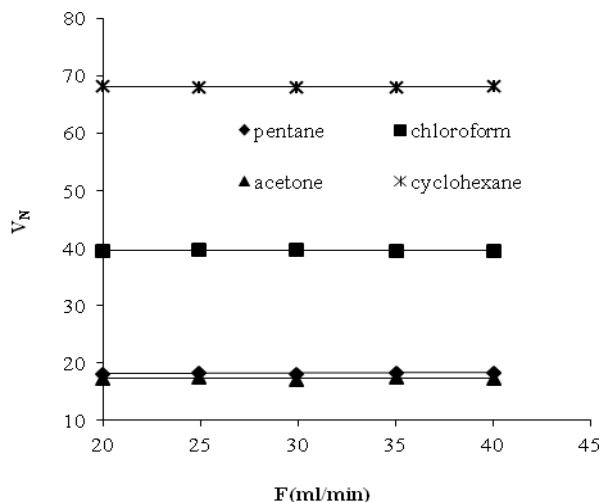

Fig. 7 Effect of carrier gas flow rate on net retention volumes (500PDMS- column 4)

#### IV. CONCLUSION

The studies on the influence of experimental variables on retention in particular temperature, flow rate, sample size and liquid loading were previously reported [19], [21]. In this paper an attempt was made to expand and explain the relationship, show the significance as well as the relevance to polymer solution thermodynamic calculations and interpretations. A wealth of physiochemical information can be obtained from chromatographic measurements. Compared to conventional techniques, the GLC gave advantages in speed, convenience, application to very small sample sizes and variety of thermodynamic information. Despite the apparent simplicity of this method, considerable care and intelligence are prerequisites for this procedure. A clear and direct relationship between theory and practice of chromatography permits the determination of variety of physiochemical information. The results of this work clearly indicate that the GLC procedure is a valuable tool in studying polymer solution thermodynamics for VOCs physical absorption feasibility studies.

#### ACKNOWLEDGMENT

The author is greatly indebted to the Department of Chemical Engineering of the University of Johannesburg for financial support. The encouragement and advice of fellow colleagues is greatly appreciated.

#### REFERENCES

- [1] O. Smidsrod, and J. E. Guillet, "Study of Polymer Interactions by Gas Chromatography," *Macromolecules*, vol. 2, no. 3, pp. 272 – 277, 1969.
- [2] K. Heberger, M. Gorgenyi, and T. Kowalska, "Temperature dependence of Kovats indices in gas chromatography revisited," *J. Chromatog. A*, vol. 973, pp. 135-142, 2002.
- [3] K. B. Sentell, N. I. Ryan, and A. N. Henderson, "Temperature and salvation effects on homologous series selectivity in reversed phase

- liquid chromatography,” *Analytical Chimica Acta*. vol. 307, pp. 203-215, 1995.
- [4] B. Selligren, and J. H. Shea, “Origin of peak asymmetry and the effect of temperature on the solute retention in enantiomer separations on imprinted chiral stationary phases,” *J. Chromatography A*, vol. 690, pp. 29-39, 1995.
- [5] K. Bay, H. Wanko, and J. Ulrich, “Absorption of Volatile Organic Compounds in Biodiesel: Determination of Infinite Dilution Activity Coefficients by Headspace Gas Chromatography,” *Inst. Chem. Eng. Trans IChemE*. vol. 84, no. A1. pp. 22-28. 2006.
- [6] U. Domanska, and A. Marciniak, “Measurements of activity coefficients at infinite dilution of aromatic and aliphatic hydrocarbons, alcohols, and water in the new ionic liquid [EMIM] [SCN] using GLC,” *J. Chemical Thermo*, vol. 40. pp. 860-866, 2008.
- [7] E. Tudor, “Temperature dependence of the retention index for perfumery compounds on a SE – 30 glass capillary column I. Linear Equations,” *J. Chromatography A*, vol. 779, pp. 287-297, 1997.
- [8] E. Tudor, and D. Moldovan, “Temperature dependence of the retention index for perfumery compounds on a SE – 30 glass capillary column II. The hyperbolic equation,” *J. Chromatography A*. vol. 848, pp. 215-227. 1999.
- [9] C. S. Lee, and W. J. Cheong, “Thermodynamic properties for the solute transfer from the mobile to the stationary phase in reversed phase liquid chromatography obtained by squalane – impregnated C18 bonded phase,” *J. Chromatography A*. vol. 848. pp. 9- 20, 1999.
- [10] M. Makela, and L. Pyy, “Effect of temperature on the retention time reproducibility and on the use of programmable fluorescence detection of fifteen polycyclic aromatic hydrocarbons,” *J. Chromatography A*. vol. 699, pp. 49-57, 1995.
- [11] F. H. Pollard, and C. T. Hardy, *Vapour phase chromatography*, London, 1957, pp. 115.
- [12] P. E. Porter, C. H. Deal, and F. H. Stross, “The determination of partition coefficients from gas-liquid partition chromatography,” *J. American Soc.*, vol. 78, pp. 2999-3006, 1956.
- [13] R. N. Lictenthaler, R. D. Newman, and Prausnitz, “Specific retention volumes from gas liquid chromatography for Poly (dimethylsiloxane) – Hydrocarbon systems,” *Macro.*, vol. 6, no. 4, pp. 650 – 651, 1973.
- [14] D. C. Locke, “Chromatography for making physiochemical measurements,” *Chromatography*, vol. 1, no. 2, pp. 77 – 85, 1977.
- [15] D. H. Desty, A. Goldup, G. R. Luckhurst and W. T. Swanton, *Gas Chromatography*, Butterworth, London, 1962, pp. 67
- [16] W. R. Summers, Y. B. Tewari, and H. P. Schreiber, “Thermodynamic interaction in Polydimethylsiloxane – Hydrocarbon systems from Gas Liquid Chromatography,” *Macromolecules*, (1972), Volume 5, 12 – 16
- [17] H. Purnell, *Gas Chromatography*, John Willey and Sons, Ins, New York, 1962
- [18] J. R. Conder, “The derivation of thermodynamic information from asymmetrical chromatographic peaks when more than one distribution mechanism contributes to retention,” *J. Chromatogr. A.*, vol. 39, pp. 273-281, 1969.
- [19] E. Muzenda, and F. Ntuli, “Temperature effect on volatile organic compounds polydimethylsiloxane interactions,” *IJCEA.*, vol. 2, no. 6, pp. 376-380, 2012.
- [20] B. Selligren, and J. H. Shea, “Origin of peak asymmetry and the effect of temperature on the solute retention in enantiomer separations on imprinted chiral stationary phases,” *Journal of Chromatography A*, vol. 690, pp. 29-39, 1995.
- [21] E. Muzenda, M. Belaid, and F. Ntuli, “Measurement of infinite dilution activity coefficients of selected environmentally important volatile organic compounds in polydimethylsiloxane using gas – liquid chromatography,” *Korean J. Chem. Eng.* vol. 27, no. 5, pp. 1509–1512, 2010.