

Design of an Innovative Accelerant Detector

Esther T. Akinlabi, Milan Isvarial, and Stephen A. Akinlabi

Abstract—Today, canines are still used effectively in acceleration detection situation. However, this method is becoming impractical in modern age and a new automated replacement to the canine is required. This paper reports the design of an innovative accelerant detector. Designing an accelerant detector is a long process as is any design process; therefore, a solution to the need for a mobile, effective accelerant detector is hereby presented. The device is simple and efficient to ensure that any accelerant detection can be conducted quickly and easily. The design utilizes Ultra Violet (UV) light to detect the accelerant. When the UV light shines on an accelerant, the hydrocarbons in the accelerant emit fluorescence. The advantages of using the UV light to detect accelerant are also outlined in this paper. The mobility of the device is achieved by using a Direct Current (DC) motor to run tank tracks. Tank tracks were chosen as to ensure that the device will be mobile in the rough terrain of a fire site. The materials selected for the various parts are also presented. A Solid Works Simulation was also conducted on the stresses in the shafts and the results are presented. This design is an innovative solution which offers a user friendly interface. The design is also environmentally friendly, ecologically sound and safe to use.

Keywords—Accelerant detector, Canines, Gas Chromatography-Mass Spectrometry (GC-MS), Ultra Violet light.

I. INTRODUCTION

CANINES have been used as chemical detection for thousands of years due to their superior sense of smell. Over the last century, the use of the canine nose has been expanded into many fields such as drug detection and accelerant detection. However, training of the dogs has become expensive and impractical. Accelerants are generally substances that speed up a chemical process or could aid the spread of fire. A fire accelerant is a substance that causes or aids a fire. There are many types of accelerants throughout the industry. Accelerants are usually a mixture of solvents that are organic based. Examples of different types of accelerants include: Kerosene, paint thinner, Gasoline etc. These substances are also referred to as petroleum distillates. In the automotive industry however, there are only a few accelerants that are of vital importance. These are; petrol, diesel and lubricating oils [1]. A fire in the automotive industry can be extremely dangerous due to the fuel (petrol or diesel) that is in

the fuel tank. It is also important to know if any accelerant is found in the debris of a fire in the automotive industry. If accelerant is found, it is important to know the source of the accelerant. Fires that are caused by leaks in fuel tanks or other parts of a vehicle should be identified. If this is the case, the vehicle should be taken off the market until the problem is rectified and the vehicle is safe to drive again to avert fire accidents. Accelerant detection is an important process that allows people to determine the cause of a fire. However, the process of unique detection of an accelerant such as petroleum is a difficult task [2]. Petroleum accelerant leakage is one of the main causes of fires in the automotive industry and crashes. There are many various ways to detect the presence of accelerant in a sample of fire residue. The most common method of the detection of an accelerant is the use of canines. Canines have a very acute sense of smell and can be trained to detect accelerant in a fire site that is littered with fire debris [3-4]. This method however has a number of disadvantages. The Gas Chromatography-Mass Spectrometry (GC-MS) method is also a common method of detecting accelerants in a sample of fire debris. This method however requires tedious lab work and is time consuming and expensive [5]. Therefore, vapour phase Ultra-Violet (UV) spectrometry accelerant detection is the preferred method of detecting an accelerant in a sample of fire debris [6]. The use of UV light for the detection of an accelerant is a cost effective method. However, this method is ignored. This UV method of detecting accelerant is quick and easy. There are many advantages of using the UV light to detect accelerant in a sample of debris [7-8]. Some of these advantages in comparison to sniffers in the detection of an accelerant is the fact that the UV light can detect accelerant in older samples of fire debris while a sniffer can only detect accelerant in fire residue only up to three days after the fire has occurred. A UV light accelerant detector may be able to detect accelerant that is up to two months old. The wind usually affects sniffer devices as well as canines and can lead to false positive and negative detection. The wind however, does not affect a UV light. Canine and mechanical sniffers cannot detect an area of general saturation. This area will effectively be the source of the accelerant. A UV light however can detect these areas of saturation and the pour pattern can be seen. These are the pour trails that lead back into a device or container where the accelerant escaped from. If a fire burns for a very long time and is very hot, the odour of the accelerant is no longer present and mechanical and canine sniffers will be unable to detect the accelerant. The UV light however, will still be able to detect the accelerant [8]. These advantages of using UV light to detect the presence of an accelerant all meet the required specifications of this

E. T. Akinlabi is a Senior Lecturer in the Department of Mechanical Engineering Science, University of Johannesburg, Auckland Park, Johannesburg, South Africa, 2006 (phone: +2711-559-2137; e-mail: etakinlabi@uj.ac.za).

M. Isvarial is a graduate student of Mechanical Engineering Science, University of Johannesburg, Auckland Park, Johannesburg, South Africa, 2006.

S. A. Akinlabi is a doctorate candidate in the Department of Mechanical Engineering Science, University of Johannesburg, South Africa, 2006. (Phone: +277984-77095; e-mail: saakinlabi@uj.ac.za).

design. Generally, Gas Chromatography-Mass Spectrometry (GC-MS) is used to detect petroleum accelerants such as motor gasoline, diesel fuel and kerosene. All these fuels can be found in vehicles and can be the main cause in starting or accelerating a fire. However, gas chromatography is not the only way to detect petroleum accelerants. Petroleum accelerants are made up of hydrocarbons which emit fluorescence. Under the correct fluorescent lighting, petroleum accelerants can be detected [5]. These tests are usually performed in a laboratory. However, a mobile detector would have the advantage of detecting if an accelerant is present on site and therefore, effectively saves time and money. The need for an effective accelerant detector has always been a major concern to automotive manufacturers due to the fact that a correctly and accurate accelerant detector can greatly increase the safety of the automobile world. Canines are mostly used for accelerant detection. However, canines are not completely accurate and often have false positive and negative alerts [9]. The residue would then have to be analysed in a lab to determine what type of accelerant caused the fire. The main method of automated accelerant detection is gas chromatography. This method has some problems however. This method is conducted in a laboratory and has to be under controlled conditions. Also, sample preparations of fire residue takes an extremely long time and can be tedious. Therefore, the need to save time and money has become an important factor in the process of accelerant detection. Therefore, a need for a compact, accurate and efficient automated accelerant detector has arisen. Due to the fact that during a system failure, including loss of power, the gas chromatography setup will take some time before becoming fully operational, it may not be the correct option to choose. Vapour phase Ultra-Violet (UV) spectrometry setup is the preferred option to be used. This method does not take long to become fully operational again after a system failure [6]. UV light is a commonly overlooked solution to the problem of detecting accelerants. However, the idea is slowly being integrated into the industry. A study was conducted by McCurdy *et al* [6], on the use of Vapour phase ultra-violet spectroscopy for the analysis of arson accelerants in fire scene debris [6]. It was concluded that it is possible to use UV light to detect the presence or absence of an accelerant in a fire debris sample. This method however cannot distinguish which type of accelerant is present and further lab analysis will be required to conclusively distinguish the type of accelerant in the sample of fire debris. It was also concluded that the cost of using UV light to detect an accelerant is much less than the expensive laboratory methods often used [6]. An innovative design of an accelerant detector which utilizes the UV light is hereby presented.

II. CONCEPT GENERATION AND SELECTION

The Product Design Specification (PDS) is based on five criteria; safety, simplicity, cost effectiveness, manufacturability and maintainability. These criteria were

then compared against each other to determine the weighting of each individual criterion. This is important in selecting the best concept in this regard. The criteria are denoted as follows: C1 = Safety, C2 = Simplicity, C3 = Cost effectiveness, C4 = Manufacturability and C5 = Maintainability. Table I shows how each of the criteria was compared against each other to determine the importance of each of the criteria.

TABLE I
RANKING OF CRITERIA

Criteria	C ₁	C ₂	C ₃	C ₄	C ₅	Total	Weighting
C ₁	X	1	1	1	1	4	0.4
C ₂	0	X	1	1	0	2	0.2
C ₃	0	0	X	1	0	1	0.1
C ₄	0	0	0	X	1	1	0.1
C ₅	0	1	1	0	X	2	0.2
Total						10	

The weighting is derived by effectively obtaining the fraction of each criterion with respect to the overall total criteria. The total of the weighting is equal to 1 which thus confirms that the criteria ranking was done correctly. The weighting of the criteria are thus as follows:

$$C_1 = 0.4, C_2 = 0.2, C_3 = 0.1, C_4 = 0.1, C_5 = 0.2.$$

Therefore, safety is the most important of all the criteria which effectively is true when dealing with fire debris and therefore the ranking process can be assumed correct.

Five different concepts were thought of and the alternatives are hereby presented. All the proposed alternatives meet the design requirements in one way or the other. However, the best alternative was selected from the various concepts generated as presented in this section.

A. Concept 1

This alternative is a pyramid shaped design as shown in Fig. 1.

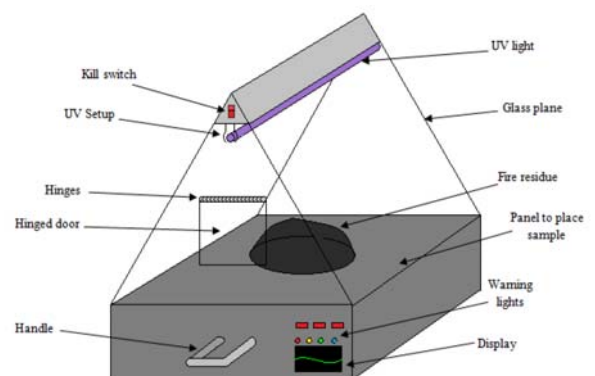

Fig. 1 Concept 1, the pyramid shaped design

The glass plane allows for easy viewing of the debris and ensures that it is to determine if an accelerant is present or not. This design has handles on the sides and makes it easy for the detector to be carried around. There exists a hinged door to insert the fire residue. All necessary warning lights and displays are also incorporated. Also, a kill switch is located in an easy access place. One major flaw in this design concept is

that it is hard to transport and it is not user friendly. However, this design is compact.

B. Concept 2

This design is aimed at being easy to transport. However, this means that it must also have less weight. The straps on the device act as a carrying medium. This device has to be operated manually as shown in Fig. 2.

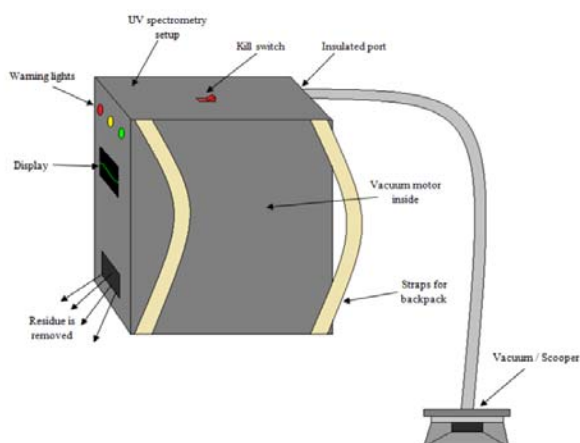

Fig. 2 Concept 2, with straps for backpack

The hose has to be hand operated. The UV setup is incorporated into the design. The function of the vacuum is so that the person handling the machine will not need to touch any of the fire residues. This could be advantageous in avoiding contamination of the samples being tested. Also, this could be a safer method of obtaining samples than touching them physically. All warning lights are incorporated into the design as well as an easy access kill switch in event of emergencies. The hose is insulated to prevent contamination. This design also has a port that emits the residue after testing has been performed for a safety purposes.

C. Concept 3

In the design concept 3, the wheels are incorporated into the design as shown in Fig. 3.

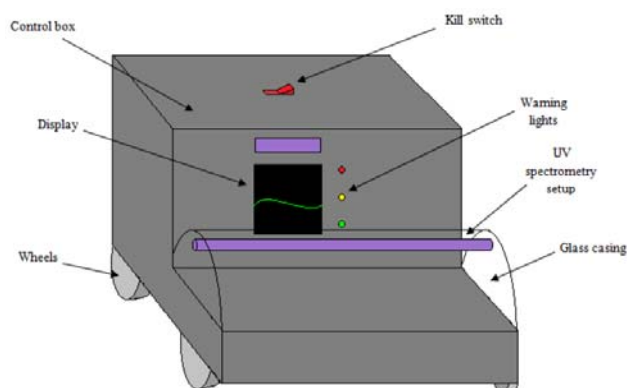

Fig. 3 Concept 3, a design with wheels

The wheels were incorporated to solve the transportation problem that the previous devices had. The device can now be

transported around. The cover glass casing is also incorporated into this design. This device also has a plug port to recharge the device. This is a major advantage as the device can access areas that were previously out of reach. All warning lights are incorporated into this design as well as a kill switch in an easy access position. The UV setup is installed in the device and the casing opens and closes freely with hinges.

D. Concept 4

Concept design alternative 4 is a new and innovative idea as presented in Fig. 4.

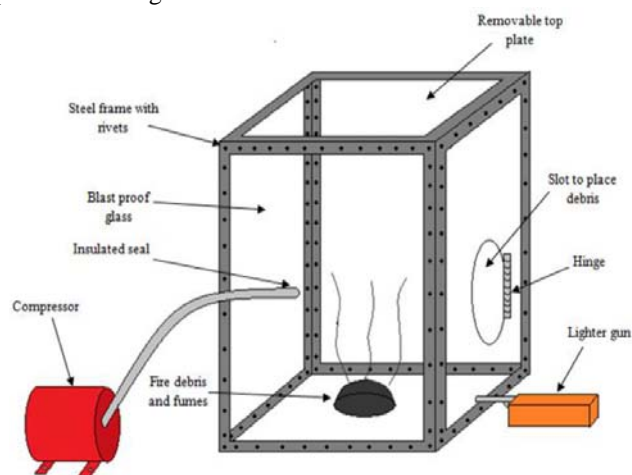

Fig. 4 Concept 4 design with a lighter gun

The idea is a simple system capable of detecting the presence of accelerants in fire residue. The remaining fire residue contains hydrocarbons, the fumes given off by the hydrocarbons may be flammable and therefore this design incorporate the concept of flammable accelerant fumes. The frame is made of steel and riveted together with the glass. The top of the frame is removable in case of violent explosions. The glass casing is made of blast proof and bullet proof glass for safety purposes in case of violent explosions as mentioned before. The compressor serves to pump air into the case to ensure that the right mixture of fuel and air can be obtained. This optimum mixture guarantees that the fumes will ignite. There is a major disadvantage to this design however; safety is a major concern for this particular concept. A violent reaction could cause harm to persons and equipment.

E. Concept 5

This design also incorporated wheels into the design as shown in Fig. 5.

However, these heavy duty wheels are ideal for unstable and messy accident sites. This design has the advantage of having a tanker. More loads can be handled and can be operated in a rough environment.

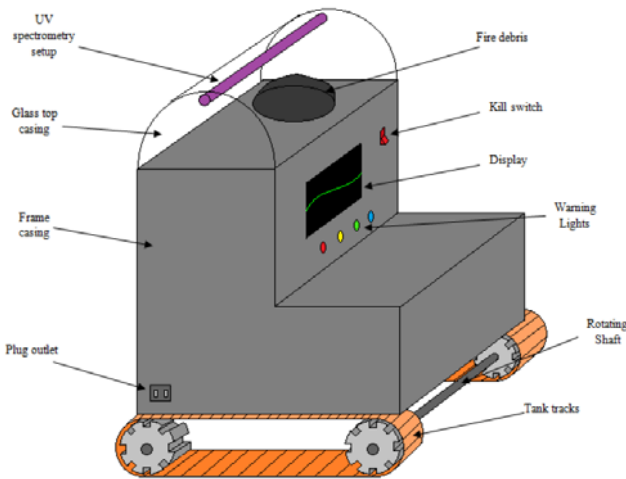

Fig. 5 Concept 5 with tank tracks

This design also incorporates the glass casing effectively. The wheels on this device can be four-wheel drive to ensure that any crash site can be accessed. Climbing over rubble and burnt material is also easy with this design. The design can either be operated as a fully automated device or can be manually controlled. A motor is installed to provide drive to the wheels. A plug inlet is available for charging. The device also incorporates the UV spectrometry system and this is built into the design. The display is large and the device is user friendly. Warning lights are also installed in correct places in case of emergencies as well as a kill switch in a quick and easy access point.

The selection of the best alternative was then conducted which entirely depend on how it compares to other alternatives while comparing them to the criteria weighting at the same time. Concept five had the highest rating in terms of safety, simplicity, cost effectiveness, manufacturability and maintainability and was therefore chosen for detailed design. It has a kill switch which is located in an easy-to-access position that ensures that the device can be shut down immediately in case of a malfunction during the operation of the device. The tank track design ensures that the device can access all areas of the fire site. The device can reach places on the fire site that no normal wheeled device can reach. The UV setup is located in an easily assessable position glass casing which is easy to clean and maintain. Any accelerant present will be able to be viewed quickly and easily. Plug outlet ensures that the device can be charged up and used for several hours. This implies that the device is electrically powered and therefore more environmentally friendly. This concept device is easy to maintain and therefore, the device is cost effective in the long run. The strong frame ensures that a lot of debris can be tested for an accelerant at one time. The device is stable due to the tank tracks and can easily climb over rubble and debris in various locations.

III. PERFORMANCE EVALUATION AND SIMULATION

The UV spectrometer is capable of detecting small amounts of accelerant in the fire residue. The hydrocarbons in the fuel emit a florescent glow on exposure to the UV light. This is the main method of detecting the accelerant in the fire residue in this design.

A. Material Selection

Material selection is a major design consideration. The material should be selected according to the product design specifications and the specific properties of the materials. The material must also fit the specific need and function that it was selected to for. For the frame, a light weight metal was required to ensure that the device does not exceed the PDS of being light weight. Therefore, the frame is to be made out of aluminium. Aluminium meets the specifications of the PDS of the device. The properties of aluminium are optimal for this frame design. Aluminium is a typical metal and can be easily melted, cast and formed. The light weight nature of aluminium ensures that the frame is strong yet light. In addition to its light weight, aluminium is corrosive resistant which is ideal when working with accelerants in this regard. Aluminium has very good reflective properties to both light and heat. Therefore, any remaining heat from the fire debris will be reflected safely away. Aluminium is also recyclable and this makes the device more environmentally friendly. The glass casing is to be made from UV based laminated glass. This material is ideal for the glass casing [10]. The laminated glass is impact resistant and will therefore be ideal for handling. The UV based laminated glass will ensure that most of the UV light will be trapped inside the glass casing. This will be helpful when detecting the accelerants. This glass will therefore ensure that the viewing and detecting of an accelerant is quick and easy. It is always a good practice to design shafts using mild steel. This material can be changed if the stress exceeds the maximum allowable stress and the deflection exceeds the maximum amount of deflection. Mild steel is readily available and can be found easily. The material is also cheap.

B. Simulation of the Shaft System

The front shaft was subjected to loading and torque in the Solid Works Simulation program. First, the ends of the shaft were fixed and then the loading and the torque was applied as shown in Fig. 6. The maximum deflection seen in the shaft was 0.3082 mm. This is acceptable for this designed shaft and therefore redesign was not needed. The simulation also displayed this value which is shown in Fig. 7.

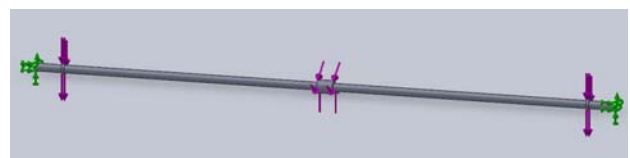

Fig. 6 Loading Simulation of Front Shaft

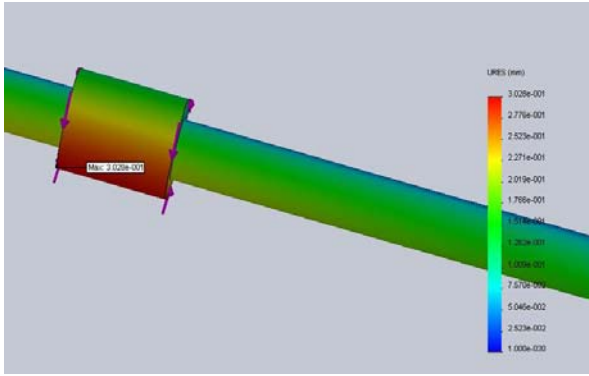

Fig. 7 Deflection of the Front Shaft

The Von Mises stress was also calculated and the maximum stress was less than the yield strength of the material chosen. Therefore, the shaft is a safe design and will not fail easily. The Von Mises stress analysis is shown in Fig. 8.

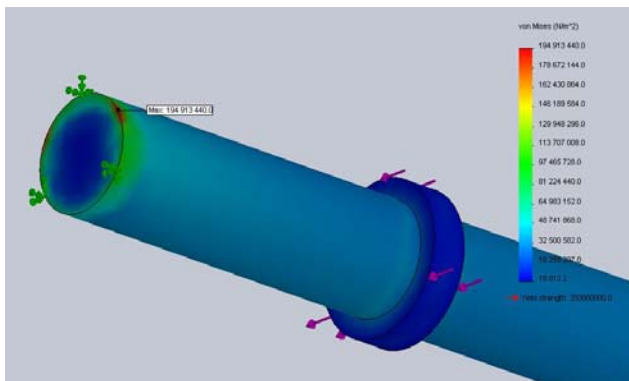

Fig. 8 The Maximum Von Mises Stress in the Front Shaft

From these values, the shafts can be assumed to have been designed correctly and therefore the shafts can and will support the torque of the motor and the load of the frame.

IV. SAFETY FEATURES AND CONSIDERATIONS

Safety is one of the most important factors to consider when designing a system or device. The system has been designed in way as not to intentionally harm any living creature. It is expected that the device will only be operated by persons over the age of eighteen years old and are specially trained to handle such equipment. A kill switch is incorporated in the design to ensure that in case of emergencies, the device can be shut down quickly to prevent harm to the operator or others. The machine should adhere to all ASTM standards which include all government fire regulations for operation on site after a fire. Any burning debris should not be approached without a professional at all times.

V. CONCLUSION

The design of an innovative accelerant detector has been presented. This design used Ultra Violet (UV) light technology to detect the presence or absence of an accelerant in a sample of fire debris. All the Product Design

Specifications (PDS) were met which resulted in a simple yet innovative design. The relevant literatures were reviewed and from these, five concepts were generated. The best concept was chosen using the systems engineering approach and this became the main design. This was alternative concept 5. Performance analysis on the chosen concept was conducted. This process ensured that the design incorporated the UV setup as well as the tank tracks correctly. The design is energy efficient and environmentally friendly as it does not produce harmful gases or substances. The design is simple and easy to manufacture. The device is also safe to use indoors and outdoors and the user interface is easy to operate. The device does not emit any toxic or harmful gases that could affect the environment or living creatures. Therefore, this innovative yet simple design is a response to the need of an effective accelerant detector, which can detect the presence or absence of an accelerant when loaded with fire residue.

ACKNOWLEDGMENT

The financial support of the University of Johannesburg research fund is acknowledged.

REFERENCES

- [1] Science Resources (2009) science-resources.co.uk. [Available Online]. http://www.science-resources.co.uk/KS3/Chemistry/Chemical_Reactions/Hydrocarbons/Distillation.htm
- [2] E Du Pasquier and P. M. L. Sandercock. "Chemical fingerprinting of unevaporated automotive gasoline samples". *Journal of Forensic Science International*, 2003; 134: p. 1–10.
- [3] L. Yizhar, B. Gil, A. Ophir, G. Allen, T. Joseph and G. Irit. "A simple system for the remote detection and analysis of sniffing in explosives detection dogs" *Journal of Behavior Research Methods, Instruments & Computers*. 2003; 1(35): p. 82-89.
- [4] G. Schaffer. (2009) Outside K9. [Available Online]. <http://outsidek9.com/tag/canine-accelerant-detection-association/>
- [5] T. Shigeki and S. Naoki. "Fluorescence imaging of petroleum accelerants by time-resolved spectroscopy with a pulsed Nd-YAG laser". *Journal of Forensic Science International*. 2006; 163: p. 38–50.
- [6] T. Atwell, D. Michael, R. Cole and J. McCurdy. "The use of vapour phase ultra-violet spectroscopy for the analysis of arson accelerants in fire scene debris". *Journal of Forensic Science International*, 2001, 123; p. 191-201.
- [7] Ultra Violet Products (UVP). (1997) Ultra Violet Products web site. [Available Online]. <http://www.uvp.com/pdf/ab-107.pdf>
- [8] Labino. (2007) Crime - UV and Fire Investigations. [Available Online]. <http://www.labino.com/pdf/Crime%20-%20UV%20and%20fire%20investigation.pdf>.
- [9] E. Wagner. (2010) TC Forensic. [Available online]. <http://www.tcforensic.com.au/docs/uts/essay2.pdf>
- [10] C. Vargas. (2006) UV-Curable Interlayers for Glass Lamination. [Available Online]. The Design of an Accelerant Detector. http://d67576.u25.creativeedge.com/Industry/pdf_articles/uvglasslammayjun06.pdf