

Reagent Optimization across a UG2 Plant

Edison Muzenda, *Member, IAENG* Ambali S. Abdulkareem, *Member, IAENG* and Ayo S. Afolabi, *Member, IAENG*

Abstract— Reagent optimization is very important in the recovery of valuable metals from their ore via flotation. This is particularly important for large platinum operations where correct reagent regime and addition system can provide improvement opportunities in recovery and grade. Also reagent optimization can reduce reagent costs for the rougher, scavenger and cleaner flotation units. Reagents were optimized in the flotation of hot floats from the plant at laboratory scale. It was found that in order to save cost, the collector and depressant must be reduced in the roughers and cleaners respectively. This report presents results and some practical considerations that must be taken into account to optimise reagent usage.

Keywords— collectors, depressants, frothers, flotation, hot float, recovery

I. INTRODUCTION

In order to extract the pure metals from the rock containing concentrations of PGMs, the ore is firstly comminuted by crushing and milling to reduce the size of the rock particles and to expose the minerals which contain the PGMs. The comminuted particles are then mixed with water and reagents in a flotation process while air is pumped into the resulting pulp to create bubbles to which the PGM-containing particles adhere. These float to the surface and are removed as a soapy froth, while the barren material remains in the pulp and eventually discarded. Usually, the material which fails to float the first time goes to the secondary milling and flotation circuit in order to extract as much PGM as possible. This process is described in details in Fig. 1.

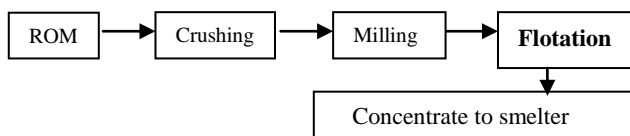

Fig. 1. Basic flow process within a concentrator

Manuscript received March 6, 2013; revised April 9, 2013. This work was supported in part by the Universities of South Africa and Johannesburg.

E. Muzenda is with University of Johannesburg, University of Johannesburg, Faculty of Engineering and the Built Environment, Doornfontein, Johannesburg, P O Box 17011, 2028, South Africa (e-mail: emuzenda@uj.ac.za).

Ambali S. Abdulkareem is with University of South Africa, Department of Chemical Engineering, Florida, Johannesburg, South Africa, and Department of Chemical Engineering, School of Engineering and Engineering Technology, Federal University of Technology. PMB 65, Gidan Kwano, Minna, Niger State, Nigeria (e-mail: kasaka2003@yahoo.com).

Ayo S. Afolabi is with University of South Africa, Department of Chemical Engineering, Private Bag X6 Florida, Johannesburg, South Africa. (Corresponding author: Tel: 0027114713617, Fax: 0027114713054, e-mail: afoalaas@unisa.ac.za).

The process of recovering platinum group metals (PGMs) by flotation from different parts of the UG2 reef is an intensive one especially in terms of reagent utilization [1 – 4]. Each operation has developed a specific reagent suite for the optimum recovery of PGMs from their particular UG2 deposit and this has led to a variety of different reagents being used to recover these valuable minerals. Over the time, a lot of money has been invested to study different types of reagents in order to optimize the recovery of these valuable metals from the run of mine.

Reagent optimization is an important consideration for large PGMs processing operations because the correct reagent regime and addition system can provide improvement opportunities to flotation recovery and grade [5,6]. Also, the cost of reagents typically runs into tens of millions of dollars per annum for a large PGMs operation, and therefore reagent optimization presents a good opportunity for cost improvement, especially in these critical financial times [7].

This study was undertaken to optimize the reagents across the UG2 circuit during the flotation process. All tests were performed using batch flotation and adding different reagents involved in the process in order to obtain the concentrate. This information was needed to compare the dosages in terms of grade and recovery data that would be obtained after conducting flotation tests. The findings from this study can further be used to study the effects of collector and depressant needed for the optimum flotation of sulphide minerals. Fig. 2 shows the flow sheet for the flotation process of a typical UG2 circuit.

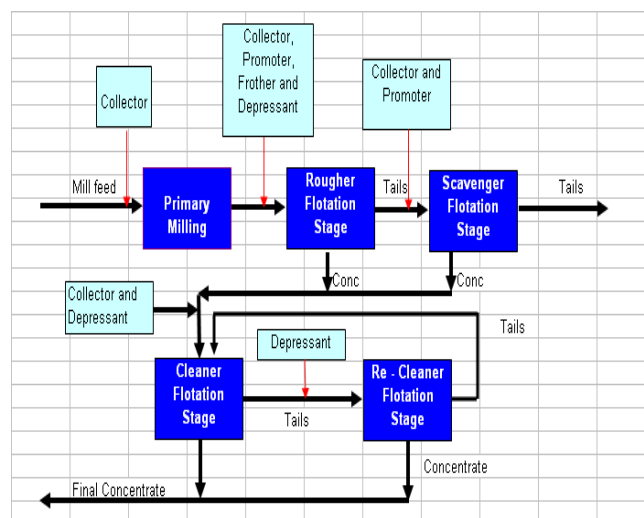

Fig. 2. Typical flow sheet of UG2 circuit

II. METHODOLOGY

Hot floats samples were collected from the Anglo platinum mines plant, after stopping the pumps which

pumps the following reagents to the Rougher, Scavenger and High Grade Cleaners circuits. The following reagents were stopped but only copper (II) Sulphate (activator) was not stopped. The spot checks on copper (II) Sulphate was done on the roughers and the scavengers by measuring (in ml/min) CuSO₄, and converting it to (l/hr) for calculation purpose.

Table 1:
Dosing point at the UG2Plant

Circuit	Reagent	Dosing point
Rougher	SIBX	Screen underflow
	SIBX	Rougher feed before splitter
	Sasfroth	Rougher feed before splitter
	M47	Rougher feed before splitter
Scavenger	SIBX	Scavenger feed
	Sasfroth	Scavenger feed
	M47	Scavenger feed
Cleaner	SIBX	High Grade Cleaner feed
	M47	High Grade Cleaner feed

CuSO₄ which was added to the mill feed and in the scavenger feed was not stopped. Spot-check of CuSO₄ was done in order to check as amount in the circuit. Spot-check was done using the 1000 ml measuring cylinder where the CuSO₄ solution was filled to the measuring cylinder and measured after one minute. The ml/min was then converted to g/t to check the dosage of CuSO₄.

After stopping the reagents (Table I) for 15 minutes, the samples were taken from the following sampling points; Rougher feed, Scavenger feed, and High Grade Cleaner feed. Buckets were used for sampling and care was also taken during sampling where the bucket was filled to exactly 4.5 litres and no sample was allowed to split out of the sample scoop which was going to bias sampling. After taking the samples the buckets were closed tightly to make sure little or no air could enter the sample to avoid oxidation.

The samples were then taken to the laboratory where the mass of the samples were measured then the sample was transferred to the 4.5 L flotation cell. The flotation cell was fitted with a variable speed drive and the pulp level was controlled manually by the use of plant water. The impeller speed was 1200 rpm.

The frother used for all the batch flotation tests was Sasfroth 200 at fixed dosage of 40 g/t for Rougher, 35 g/t for Scavenger and nothing was added at the High Grade Cleaner sample. The collector used was SIBX while the depressant used was M47 for all the batch flotation at different dosages as shown in Table II.

Table II
Different dosages used at different plant streams

Reagent	Circuit	g/t	g/t	g/t	g/t	g/t
SIBX	Rougher	0	47.5	90.0	142.5	180.0
	Scavenger	0	22.5	45.0	67.5	90.0
	H.G. cleaner	0	15.0	30.0	45.0	60.0
M47	Rougher	0	20.00	40.0	60.0	80.0
	Scavenger	0	17.50	35.0	52.50	70.0
	H.G. cleaner	0	150.0	300.0	450.0	600.0

During flotation three concentrates were collected at 3, 10 and 20 minutes of flotation time by scraping the froth

into a collecting pan every 15 seconds. The head sample was taken for every test which was conducted. Head samples, concentrates and tails were filtered, dried and weighed before to be taken for assay analysis. All the batch flotation tests were conducted in triplicates

A. Reagents Preparations

Sodium Isobutyl Xanthate (SIBX): This reagent was used as the collector at strength of 20g/l (2%). About 20 g SIBX powder was weighed with a spatula from its suitable container, and put in a 1000 ml volumetric flask. Distilled water was added up to a 1000 ml and the flask was shaken well for all the SIBX to be thoroughly absorbed. This reagent was used immediately after mixing.

Carboxymethylcellulose (CMC): This reagent is commonly known as M47 and 10 g of M47 powder was used. Distilled water was added to the volumetric flask containing the stirrer inside. The powder was slowly added while stirring in order to avoid causing lumps. After adding, then water can be added up to a 1000 ml and left steering for an hour, to make sure that powder is dissolved completely which was used after an hour of mixing.

Sasfroth: This reagent was used as a frother and it was collected at the mixing point of the plant for all the reagents used. The strength of Sasfroth from the plant was 1000 g/l, so it was diluted to 10 g/l (1%) by taking 10 g of Sasfroth 200 and pouring 1 litre of distilled and checking whether the strength is 10 g/l using the refractometer.

B. Experimental Procedure

The samples were taken from the plant streams with a bucket before the addition of reagents. The reagent addition was stopped for 15 mins in the plant, in order to sample the slurry that does not have reagents. This slurry was taken at the same time in order to avoid the change in particle distribution and percentage solids in the slurry. The sample from the plant was floated using the current standard conditions, and the results were used as reference for benchmark purposes. For optimization of depressant and collector, 18 tests were performed for each and will also require about 45 litres of slurry for each. Test work was done immediately after taking the sample from the plant. This was done to avoid the possibility of the sample to get edged (due to oxidation). The sample which represented the entire test work was mass balanced for accuracy as well as scrutinized for reasonability with the specific plant conditions. Selected sample was analyzed for PGMs – Cu, Ni, S and Cr₂O₃.

C. Sampling Procedure

Three sampling points identified are: the **Rougher feed**, the **Scavenger feed** and the **High grade cleaners**. The reagents (SIBX, SASFROTH and M47) were stopped for 15 minutes but only the copper (II) sulphate (activator) was not stopped with the entire reagents. When doing the baseline, 4 buckets from the three sampling points mentioned above (12 buckets) were sampled, 3 buckets were floated and 1 bucket was used as a head sample of that point that day. Copper (II) sulphate spot check was done on a daily basis when sampling, depending on the point of sampling e.g. the roughers or the scavengers. After 15 minutes, the pumps were re-opened again in order to start pumping the reagents and 16 buckets were sampled per day when testing the dosages. One bucket out of that 16 was used as the head

sample which it was filtered and taken to the oven afterwards.

D. Flotation procedure

Three buckets were floated in order to test a certain dosage e.g. 0% collector. Two float cells were used, weighing 1388 g and the other one 2603 g with the two Denver machines at a speed of 1200 rev/min. A stopwatch was used for conditioning time of 2 minutes and the time taken to float. Plant water was used to keep the level consistent and to rinse the float cell while floating. The first concentrate was floated for 3 minutes, the second one for 7 minutes and the third one for 10 minutes. When floating for a test, the float cell was scrapped after every 15 seconds and water was added in the same time for all 3 buckets. During floating, the concentrates were scraped into a pan covered with the filter paper and put into an oven. After floating each bucket, the tails were filtered and put into an oven. Water recoveries were measured for the baseline test only. Feeds, concentrates and tails were filtered, dried and weighed before analysis. It has been assumed that the analysis of the sulphide minerals recovered in the concentrates gives an indication of PGMs recovery due to the strong association between the sulphides and PGMs in this particular ore. All batch flotation tests were conducted in triplicates. The dry masses of the rougher samples were pulverized, screened and spitted in order to keep back-up samples. On the scavengers and the cleaners, the samples were not spitted because the mass was limited

III. RESULTS AND DISCUSSION

A. Rougher Stream

The stage distribution of reagents down a flotation bank is practiced in many operating plants to give a boost to the flotation after the first cells [8]. A typical reagent distribution uses more than 75% of the collector at the top of the flotation bank with the remaining distributed down the bank. Results of exploratory laboratory and full scale trials show that by using 50% or less amount of collector at the top of the bank, with larger additions in the downstream cells provides higher recovery of coarse particles at equivalent or lesser reagent consumption. This lower addition at the top of the bank is sufficient to allow the flotation of fine particles. The remaining collector can then adsorb on the coarser particles that require more surface coverage to be recovered by flotation. In addition, to show an improvement in the recovery of coarse particles, the tests with low addition of collector at the top of the flotation bank yield higher recovery of fine particles.

Fig. 3 shows that by adding 25% of what was added at the plant, more or less the same amount of grade and recovery was achieved. The Fig. indicates that the collector was wasted and therefore must be reduced to lower the costs. This means that less collector is needed in the rougher because the material in the rougher section are fast floats. A depressant must be added for high selectivity purpose. It is therefore recommended that about 50% less collector should be used as a dosage in the rougher section.

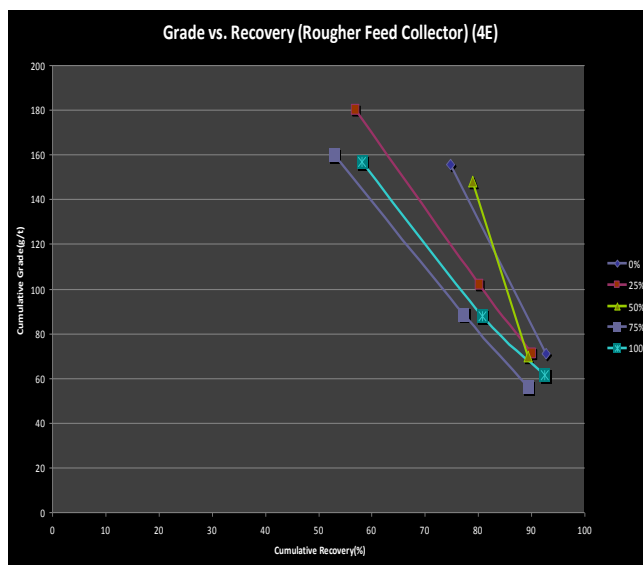

Fig. 3. Grade vs. recovery on the rougher feed collector

Depressant CMC, is usually employed to reduce the floatability of naturally floatable gangue minerals (NFG) present in the ore [7,9,10]. In this case, a depressant was used to increase the selectivity of the collector. The dosages and ratios of the various reagents used also vary significantly. A careful observation of the 50% curve (what is currently added at the plant), shows that the depressant is needed or valued as it increases the grade. At 100% 4E curve shows that a higher grade and the same recovery in the rougher section can be achieved if only the dosage of the depressant can be increased (Fig. 4).

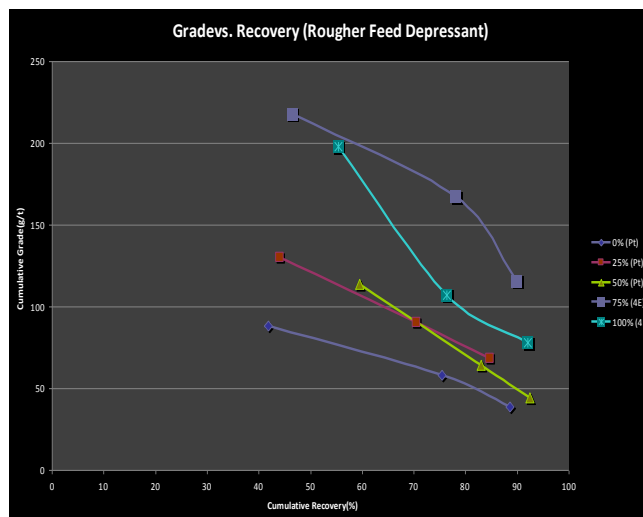

Fig. 4. Grade vs. recovery on the rougher feed depressant

B. Scavenger Stream

Fig. 5 shows that the grade can be increased by doubling collector used at the same recovery. But again, this Fig. also shows that the dosage is still reasonable the way the collector is being currently dosed at the plant. This means that the collector was properly added at the plant or it can also be seen or taken that it is that wasted because the high grade can be achieved in a lesser amount of it.

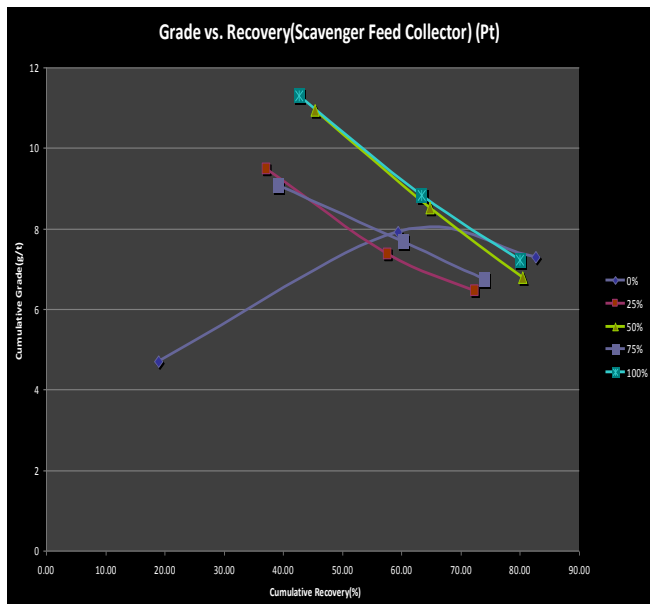

Fig. 5. Grade vs. recovery on the scavenger feed collector

Fig. 6 shows 50% as the accurate dosage for scavengers because of the high-quality grade and recovery prediction. The depressant dosage currently added at scavenger section at the plant is reasonable and best as it gives the best results. The plant needs to add a little more of depressant to scavengers to suppress more of gangue that is still contained in the slurry.

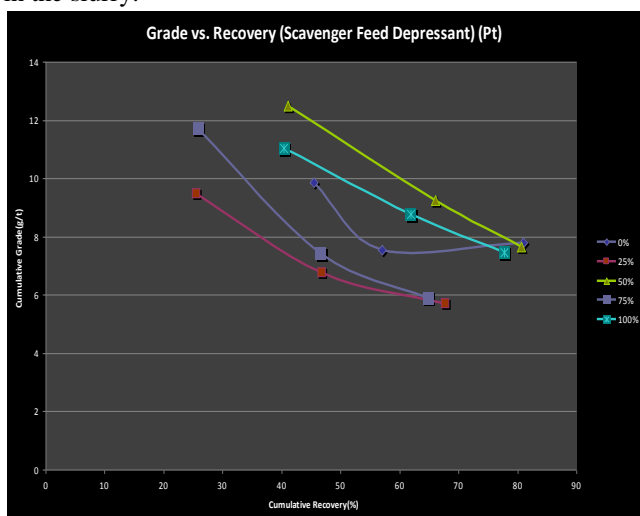

Fig. 6. Grade vs. recovery on the scavenger feed depressant

C. Cleaner Stream

By increasing the collector twice from what is dosed at the plant currently shows that a higher grade and recovery can still be achieved. This indicates that the cleaners accept collectors to concentrate more. The collector is accurately dosed at the plant (Fig. 7).

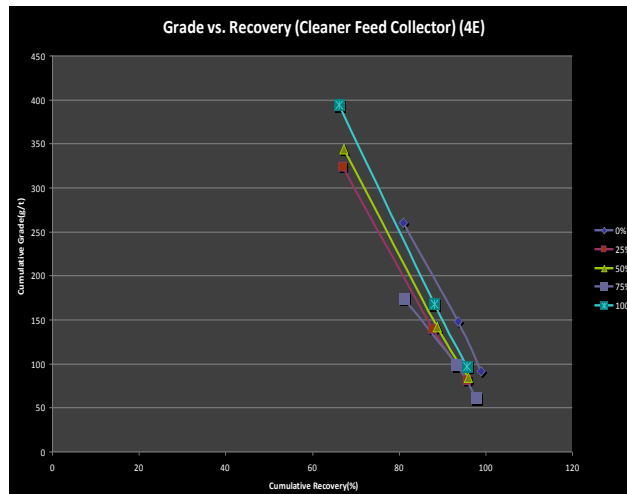
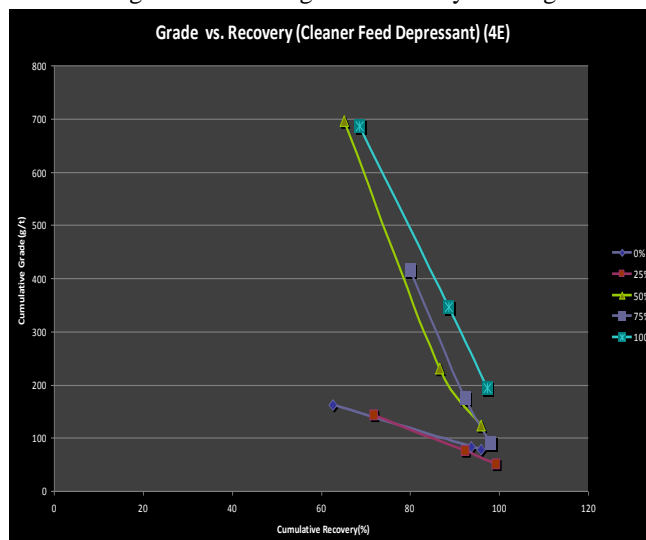

Fig.7: Grade vs. recovery on the cleaner feed collector

In the same vein, the current dosing (50%) is good because it gives a good grade and recovery (Fig. 8). It can also be observed from this Fig, that not enough depressant can be dangerous because it decreases the grade. A close observation at the 25% and 0% curves shows the evidence for the low grade even though the recovery is still good.



Graph 6: Grade vs. Recovery on the cleaner feed depressant

Bradshaw et al. [11] suggested that, in the case of the depressants, the greatest effect was that of increasing dosage, in both reducing floatable gangue, as the primary effect and also in reducing the sulphide recovery as the secondary effect. The implication of this is to avoid overdosing of depressants irrespective of type. As also stated by Martinovic et al [9] depressant CMC, is used to reduce the floatability of naturally floatable gangue. However, in the industry there is believe that excessive depressants should be used and this is attributed to less concentrate mass pull. Therefore, it is vital to find the balance in all the streams because the mass pull differs in all the streams. This is extremely important as the excessive dosage of CMC depressant decreases concentrate solid density hence more valuable particles are not floated, as a result the PGMs are washed away through entrainment.

III. CONCLUSION

From the analyses of the results obtained in the optimization of reagents during the flotation process of UG2 ore, it can be concluded that lesser collector was needed in the roughers because the materials at this section are fast floats hence the collector dosage should be decreased as this will save the cost without affecting the grade and recovery. In the same vein, a bit of depressant should be dozed at this section to increase the selectivity of the collector, at the same time to reduce the naturally floating gangue minerals (NFG) present in the ore. At the scavenger section, the plant collector dosage was accurate as it produced good recovery and grade while the depressant dosage must be increased. At the cleaners section, the collector dosage must be slightly increased while lesser depressant must be dozed. It can also be concluded that, the re-circulation load does not have any effect on the scavengers.

ACKNOWLEDGMENT

The authors gratefully acknowledge the financial support of the Universities of Johannesburg and South Africa.

REFERENCES

- [1] R. C. Santana, A. C.C. Farnese, M. C.B. Fortes, C. H. Ataíde, M, A.S. Barrozo, "Influence of particle size and reagent dosage on the performance of apatite flotation" *Separation and Purification Technology*, Vol. 64, 2008, pp. 8-15.
- [2] C. Bazin and M. Proulx, "Distribution of reagents down a flotation bank to improve the recovery of coarse particles" *Int. J. Miner. Process.* Vol. 61 (2001), pp. 1-12.
- [3] Wiese, J.G., Becker, M., Bradshaw, D.J. and Harris, P.J. "Interpreting the role of reagents in Flotation of platinum bearing Merensky ores". International Platinum conference 'Platinum Surges Ahead, the Southern African Institute of Mines and Metallurgy, 2006, pp. 175-177.
- [4] J. Wiese, P. Harris and D. Bradshaw, "The Response of sulphide and gangue minerals in selected Merensky ores to increased depressant dosages" *Minerals Engineering* Vol. 20 (10) (2007), pp. 986-995.
- [5] D.J. Bradshaw, B. Oostendorp and P.J. Harris, "Development of methodologies to improve the assessment of reagent behaviour in flotation with particular reference to collectors and depressants" *Miner. Eng.* Vol. 18 (2005), pp. 239-246.
- [6] R.J., Pugh, "Macromolecular organic depressants in sulphide Flotation-A review: Principles, types and applications" *Inter. J. Mineral Proc.*, Vol 25, (1-2), 1989, pp. 101-130.
- [7] D. Bikak, Z. Ekmekci, D. J. Bradshaw, P.J. Harris, "Adsorption of guar and CMC on pyrite" *Minerals Engineering* , Vol. 20, (10), 2007, pp. 996-1000.
- [8] C. Bazin, M. Proulx, "Distribution of reagents down a flotation bank to improve the recovery of coarse particles" Department of Mining and Metallurgy, Laval University, Quebec, Canada G1K-7P4.
- [9] J. Martinovic, D.J. Bradshaw, and P. J. Harris, "Investigation of surface properties of gangue minerals in platinum bearing ores", 2006, pp. 349-353
- [10] D. A. Beattie, L. Huynh, G.B.N. Kaggwa, J. Ralston, "The effect of polysaccharides and polyacrylamides on the depression of talc and the flotation of sulphide minerals" *Minerals Engineering*, Vo. 19, (6-8), 2006, pp. 598-608.
- [11] D. J. Bradshaw, B. Oostendorp, P. J. Harris, "Development of methodologies to improve the assessment of reagent behaviour in flotation with particular reference to collectors and depressants" Department of Chemical Engineering, Mineral Processing Research Unit, University of Cape Town, Private Bag, PO Rondebosch, Cape Town 7700, South Africa