

# Diagnostic Methods of Frequency Response Analysis for Power Transformer Winding

## A Review

G.U. Nnachi<sup>1)</sup> and DV Nicolae<sup>2)</sup>

<sup>1)</sup> Department of Electrical Engineering, Tshwane University of Technology, EMalahleni, South Africa

<sup>2)</sup> Department Electrical and Electronic Technology Engineering, University of Johannesburg, Johannesburg, South Africa  
[gideonnnachi@gmail.com](mailto:gideonnnachi@gmail.com); [dnicolae@uj.ac.za](mailto:dnicolae@uj.ac.za)

**Abstract-** Monitoring and diagnosis of power transformers in power systems have been investigated and discussed for the past decades. Earlier detect power transformer winding failures is recommended for both manufacturing process and also for power system operators. One of the most powerful and accurate tool for sufficient winding deformation detection is considered Frequency Response Analysis (FRA) among other diagnostic methods. In this paper a review of diagnostic methods of FRA for power transformer winding are presented. Different methods of transformer winding diagnosis, with their benefits and drawbacks where investigated. Moreover, possible windings failures, diagnostic methods of FRA in Off-line and On-line power transformers, detailed advantages and disadvantages of two major types of FRA are presented. The paper was able to show that some uncertainties have not been eliminated completely.

**Keywords—** power transformers; diagnostic methods; frequency response analysis; winding deformation; off-line/on-line diagnosis.

### I. INTRODUCTION

Importance of power transformers in power system cannot be overemphasized, especially in areas where uninterrupted operation is essential for transmission and distribution systems. Hence the development of diagnostic methods devoted to electric machines/transformers should be enhanced. Mainly the early detection of winding failures in electric machines/transformers, after the manufacturing and transportation but also during operation are highly necessary because, such processes can lead to internal dislocation and damage [1], [2].

The most important equipment in transmission and distribution systems are power transformers, which are frequently subjected to various climatic conditions and as well as different electrical and mechanical conditions thereby facing continuously hazards over the course of operation [3], [4], [5]. Records testify that transformer failure especially in high voltage level like 230 kV and above causes irrecoverable problems in power system. The failure of a power transformer in active part can cause millions of dollars to restore [6]. Hence, reducing failure rate of power transformers using advanced detection techniques and smart operation should be applied as much as possible. The main hazard in power transformers is mechanical defect. It occurs due to many disturbances like unsuitable means of transporting the equipment from factory to destination, short

circuit currents, earth quakes, heavy explosion of combustible gas in transformer oil.

Such faults include [5], [6] [7]:

- winding deformation in axial and/or radial direction,
- Displacements between high and low voltage windings;
- Shorted or open turns;
- Partial winding collapse;
- Hoop buckling, tilting, spiraling;
- Core movement;
- Faulty grounding of core or screens;
- Loosened clamping structures;
- Broken clamping structures;
- Or even problematic internal connections.

Any of these defects mentioned above in active part can make transformer be out of service for a long time [3]. This is because deformed winding needs to be replaced by a new one whenever a mechanical defect occurs, which takes a long time and high costs. Therefore, it is of utmost importance to design and develop different kinds of diagnostic methods for early detection of such defects.

Further, section II will present some diagnostic methods used prior to frequency analysis, after which some specific methods involving frequency response are analyzed in section III. Conclusions and recommendations for further research are closing this paper.

### II. DIAGNOSTIC METHODS FOR MONITORING TRANSFORMER WINDINGS

Over the years, there have been several methods and strategies adopted by different scientists in order to properly detect winding or core defect of power transformers.

*A. Acoustic vibration* is one of the methods designed by some researchers to detect winding movement. Its principle of operation is to monitor the vibration picked up by acoustic sensors, using the accelerometers mounted on the tank wall [4]. It is expected that the changes in the vibration pattern should indicate changes in the transformer windings. According to [7], higher frequency signal above 2.5 kHz was found to be insensitive by the vibration signals showing that the method cannot detect deep winding movement; hence it can only be limited to be a useful tool to rank transformers for further testing by other methods such as Frequency Response Analysis (FRA) test. Therefore, it is not as effective as FRA

test in the diagnosis of the internal condition of power transformer. It was mainly used for reference information.

*B. Measurement of stray load losses* across a range of frequencies is another interesting approach by Hydro Quebec to detect winding movement in transformers [5], [6], [7]. The technique is known as Frequency Response of Stray Losses (FRSL) and it is based on the principle that axial winding displacement causes an increase in stray losses. During the test operation, the transformer is normally short circuited on the secondary winding and a low voltage signal at 20 Hz to 400 Hz frequency range is supplied to the primary winding. However, the technique is only sensitive to an axial displacement of the order equivalent to winding separation, hence it is far less sensitive than the FRA test since it is using much lower frequency.

*C. Hydraulic coupled system* as a tool for detecting winding movement was proposed by South African researchers [4]. The system is installed between the transformer winding and the core clamp structure, its fluid is transmitted to a remote receiver as a transducer. Its principle is for the core to be displaced by the hydraulic forces acting upon it, giving an output signal as a function of the forces on the piston, of which the forces are a function of the position of the actuator in the transmit cylinder and the DC output response is a function of piston displacement. The limitation of the method is that additional installation is required to be done on the power transformer and it is also blind to winding movement caused by short circuit forces.

*D. Electromechanical coupling vibration of power transformers under short circuit conditions* was proposed by Japanese researchers to detect winding displacements [8]. It was found out that the vibration of the windings increases when the deviation in the electromagnetic force as a result of the windings movement is taken into consideration. A graph of the impedance of the power frequency change versus winding displacement was plotted and the curve shows that the impedance of the transformer power frequency is sensitive to the transformer winding displacement.

#### E. Short Circuit Impedance method (SCI)

This method uses to measure the impedance of the transformer under short circuit conditions. Under the short circuit conditions the winding of the transformer are undergoing deformations due to radial, axial and combined (spiral, telescoping) forces [9] (see Fig. 1 and 2).

The SCI method developed in [9] uses to define the total short circuit impedance ( $U_k$ ) as:

$$U_k = \sqrt{U_R^2 + U_x^2} \quad (1)$$

where  $U_R$  is resistive component and  $U_x$  being the reactance component that was proposed to be evaluated as:

$$U_x = 0.2976 \frac{S \cdot c_x \cdot d_x}{2(V/N)^2 \cdot h_m \cdot N_b} K_R \left( \frac{f}{60} \right) \quad (2)$$

where:  $S$  is nominal apparent power (kVA);  $c_x = c_2 + (b_{0w1} + b_{0w2})/3$ ;  $d_x = d_{c2} + (b_{0w2} - b_{0w1})/3$ ;  $V/N =$  Volt per turn;  $h_m = h_w$  for disc type winding;  $h_m = (h_{m1} + h_{m2})/2$  average magnetic height of windings;  $N_b =$  number of limbs having windings;  $K_R =$  Rogowski Coefficient;  $f =$  operating frequency; the parameters  $c_2$ ,  $d_{c2}$ ,  $b_{0w1}$  and  $b_{0w2}$  are those shown in Fig. 3. The results are then compared with transformer specification given during commissioning.

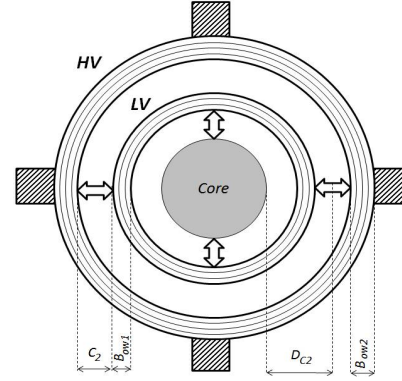

Fig. 1. Transformer winding radial movement [9]

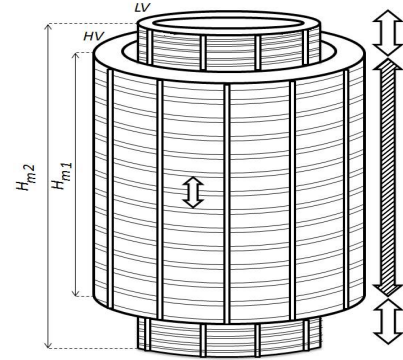

Fig. 2. Axial movement of the transformer winding [9]

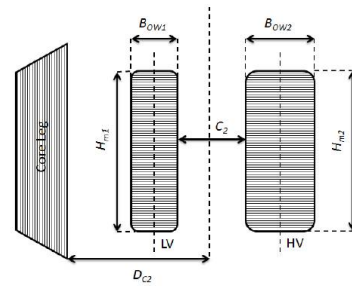

Fig. 3. HV and LV winding schematic diagram[9]

In their analysis, the authors in [2] and [9] concluded that the SCI method is sensitive to winding deformation but

mostly to radial movement and for better findings they recommend FRA for its sensitivity and accuracy.

### III. FREQUENCY RESPONSE ANALYSIS

Among other diagnostic methods, Frequency Response Analysis (FRA) is considered as a high accuracy, fast, economic and non-destructive method in detecting winding defects [9]. FRA is often used as a diagnostic tool for investigation of windings in electrical devices, mostly for identification of dislocations and deformations of transformer windings [10].

Frequency Response Analysis is accepted worldwide as one of the main techniques in diagnosing the power transformer condition, and it is especially valuable for potential mechanical problems detections like deformations or displacements in the windings and the core sheets [11], [12] [13]. It is a non-destructive test [14], [15], [9].

Based on the operational condition of the transformer, FRA has two major methods: off-line method and the later developed on-line method to eliminate down-time, assure continuity, efficient, low cost and reliable power supply [9], [16], [17], [18].

Based on the input signal, frequency response analysis can also be grouped into two:

- Sweep Frequency Response Analysis (SFRA) and
- Impulse Frequency Response Analysis (IFRA)

The SFRA and IFRA methods are normally done off-line, but recent developments show that on-line method can be applied in diagnosing the transformer using either the SFRA or IFRA method [9], [16], [10], [19], [20].

Through several literatures and series of case studies, authors in [4] and [21] were able to put forth the information in Table I, regarding the ability of the FRA to detect fault conditions.

TABLE I. ABILITY OF FRA TO DETECT VARIOUS TYPES OF TRANSFORMER FAULTS

S/N	Nature of Fault	Detectable?
1.	Mechanical Damage to windings	Detectable
2.	Mechanical damage to core	Detectable if very severe
3.	Loose turns	Detectable
4.	Short-circuited turns	Detectable
5.	Additional turns on yoke	Detectable
6.	Additional turns on limbs	Detectable
7.	Normal ageing	Detectable if very severe
8.	Winding unclamped	Detectable mostly under laboratory conditions.
9.	Foreign object	Not detectable
10.	Multiple core earths	Not detectable
11.	No core earth	Not detectable expect under laboratory conditions

#### A. Diagnostic Methods of FRA

In [23], SFRA was identified to be a powerful, non-destructive and sensitive method to evaluate the mechanical integrity of the major internal components of transformers (core, windings and clamping structures) by measuring their

electrical transfer functions over a wide range of frequencies. The method uses a low voltage sinusoidal signal of variable frequency injected in the one input/phase terminal of a power transformer winding and the response is being measured on the other respective output/phase terminal. Significantly, it considers power transformer as a complex network of R, L, C parameters, which allows the easy calculation of the electrical transfer functions.

The paper [23] also shown three methods that are normally used to interpret response signal of the transformer under test. The methods are shown below:

- Type-based (FRA of one transformer is compared to a sister unit).
- Time based (current FRA results is compared to former result of the same unit).
- Phase comparison (FRA results of one phase is compared to the results of another phases of the same transformer).

In other words, the interpretation of the responses depends on the transformer references or baseline data.

According to [24], the basic detection method to demonstrate the integrity of the windings is the reactance measurement of power transformers and swept frequency method gives better results than the Low Voltage Impulse method because the former has a finer resolution at low frequencies while the later has poor resolution at low frequencies.

Deviations of an electrical equivalent model from measured transferred functions are suggested by [25] for interpretations FRA results. The model is subdivided into two, the low frequency model and the higher frequency model. The low frequency model is normally identified from the measured transfer function by having few resonances, equivalent resonance circuits with physical meaning. While the higher parts electrically equivalent circuit could be identified using the analytical expression gained by vector fitting. It goes further to state that the issue of interpretation of FRA results is still not solved comprehensively. An objective algorithm with physical basis is still needed at the end of the day. Hence the steps taken according to the paper [22] in interpreting FRA result are:

- Low frequency model: deviations between measurements can be interpreted as changes of lumped parameters of the transformer winding.
- While the higher frequency model deviations can be interpreted as changes of poles and zeros of the analytical transfer function.

#### B. Transfer Function Method

Transfer function is basically a way of describing a system behavior. Transfer function method is increasingly used in the diagnostics of electric power equipment, especially for the identification of winding integrity in transformers [2], [9], [26]. Transfer function measurement has been developed based on two popular methods. The first one applies in time domain while the second one is concentrated on frequency domain. Frequency domain

measurement is performed by injecting a swept sinusoidal waveform within a predetermined frequency band.

$$v(t) = \sqrt{2}V \sin(2\pi f_{sweep}t) \quad (3)$$

with  $f_{min} < f_{sweep} < f_{max}$

In case of transformer studied in [9],  $f_{min}$  and  $f_{max}$  could be determined as 10 Hz and 1 MHz respectively. Although present equipment's are able to perform the injected signal up to 25 MHz, some researchers believe that acceptable and judicable result would be taken in between 10 Hz and 1M Hz [11]. In time domain method, an impulse voltage waveform is injected into the test object and time domain response measured through test object output. Once the time domain measurement data is at hand, transfer function in frequency domain could be determined by using FFT technique [9].

### C. FRA using Wavelet Transform

In an attempt by [14] to minimize noise that normally accompany the regular FRA test signals and compute the frequency response curve (impedance curve) that could allow assessment of the transformer condition, analysis of signals in Wavelet domain (time domain) was used. The Continuous Wavelet Transform (CWT) that was used in computing the transient signals exhibit better repeatability than those computed by using Fast Fourier Transform and also reveals the need of Wavelet-based de-noising strategies [16], [19], [17]. The analysis developed in [16] was applied in a single-phase distribution transformer of 7620/240V, 3kVA under load and no-load conditions, in an attempt to show the viability of the proposed method, in order to obtain the frequency response curve, to be used for transformers in service. The steps were developed to measure the transformer voltage and current transient signals in the on-line test that was employed to obtain the frequency response by injecting controlled pulses [14].

An experimental procedure for obtaining FRA with transformer on service was carried out in the Universidad del Valle's High Voltage Laboratory by injecting a controlled pulses of the voltage signal in the power transformer using an external electronic circuit [16]. A filtering technique known as Multi-resolution analysis (MRA) was used via Discrete Wavelet Transform (DWT) to process the signals. The MRA in collaboration with the DWT was used to eliminate electrical system noise. They decomposed low and high frequency signals by using high-pass  $g[n]$  and low pass  $h[n]$  filters as shown in Fig. 4.

According to the paper [16], [19], [25], the input voltage pulses and the output current signals are normally affected by the electrical system's harmonics and background noise, which is the reason why suppression signals have to be used for removing the unwanted signals. The method consisted of three stages as shown in Fig. 5. In Fig. 5:

- Stage 1 refers to injecting the low voltage pulses and its measurement along with the output current signals;

- Stage 2 dealt with signal mathematical filtering, recording and processing of the input/output signal pulses;
- Stage 3 is where the FRA curve is obtained using mathematical tools.

The method was formulated as an alternative in solving critical problems arising from the on-line FRA technique such as filtering and results' repeatability [16], [19].

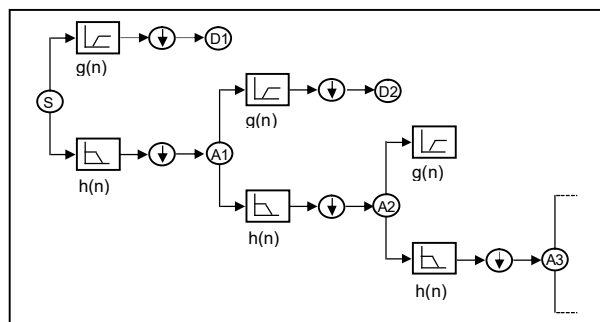

Fig. 4. Decomposed tree used for MRA analysis

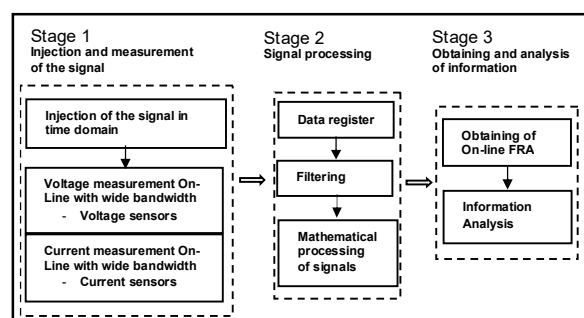

Fig. 5. FRA test stages using on-line transformers

For the online IFRA method, the tool traditionally used has been the fast Fourier transform (FFT). However, it has limitations since it requires periodic and infinite signals, while transient signals are neither periodic nor infinite [16], [14].

### D. Objective Winding Asymmetry

The Objective Winding Asymmetry (OWA) technique [25] is an extension of the low voltage impulse method, utilizing Spectral Density Estimate (SDE) building blocks to formulate the transfer function. The test results of both measurement techniques were compared with the transformer's history data and the transformer was untanked to validate the measurement. The decision for untanking was done due the conflicting results of both tests where the SFRA detected slight deformation, while the Low Voltage Impulse (LVI) measurement has detected high percentage of deformation. The untanking results revealed that the LVI is more accurate than the SFRA method [25]. However, the method could not detect minor

winding deformation and looseness due to limited frequency range (10 Hz to 1 MHz) for analysis.

An independent diagnostic system was proposed [10] in which a homemade nanosecond pulse signal generator connecting to the bushing capacitive coupling sensor (CCS) was used to produce controllable pulses as the excitation signal of transformer winding, and the bushing capacitive coupling sensor was also used for measurement of response signal as shown in Fig. 6 and 7.

A nanosecond pulse with up to MHz spectrum was used as excitation signal of transformer winding to construct Transfer Function. High Voltage bushing capacitive coupling sensor (CCS) was used as an interface through which controllable high frequency pulses with high amplitude are coupled into transformer winding, and also used to measure the response signal in the output end to extract the information (spectral density) by comparing with healthy transformer. Fig. 6 shows configuration for injecting the impulse into delta connected HV side while Fig. 7 shows injecting when HV side is star connected and grounded with  $Z_N$  impedance.

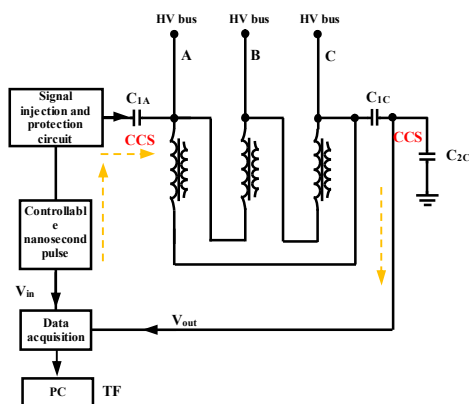

Fig. 6. Installation schematic representation of On-line monitoring diagnostic system in Delta connected network

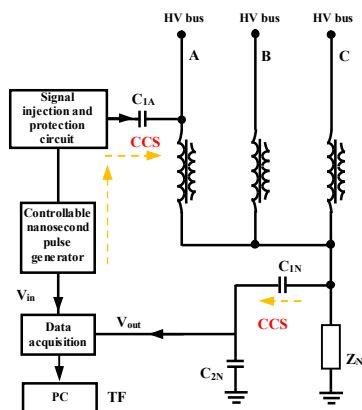

Fig. 7. Installation schematic representation of On-line monitoring diagnostic system in Wye connected network

According to [10], the use of excitation signal with enough high amplitude could eliminate the influence of poor SNR. In addition, the detection time is reduced because the nanosecond high frequency pulses have rich spectrum component. Meanwhile, the upper limits frequency of most existing commercial FRA test equipment is 1 MHz or 2 MHz. Compared with the conventional SFRA, the system extends the frequency range to several MHz for analysis, and resonance points in the high frequency band (>3 MHz) probably detect minor winding deformation.

#### IV. CONCLUSIONS

Power transformer monitoring and diagnosis have been investigated and discussed significantly for the past decades. Earlier detection of the power transformer winding failures is important to both during the manufacturing process and also in operation. Frequency Response Analysis (FRA) among other diagnostic methods is considered to be the most powerful and accurate tool for sufficient detection of winding deformation. The reviewing of diagnostic methods of FRA for power transformer winding diagnosis have been done and steps have been taken to show different methods of transformer winding diagnosis, with their benefits and drawbacks. Moreover, possible faults, which FRA can detect in power transformers, diagnostic methods of FRA in Off-line and On-line power transformers, detailed advantages and disadvantages of two major types of FRA are presented. The review shows that there are yet some uncertainties in the interpretation of the final results of FRA test on power transformers.

Based on this review, a research on impulse frequency analysis would be carried out to develop an On-line FRA analyze that can give early diagnosis of the winding condition.

#### REFERENCES

- [1] A. A. Mohamed, M. M. Medhat, "Application of Artificial Intelligence Tools in Fault Diagnosis of Electrical Machines and Drives – An Overview", *IEEE Trans. On Energy Conversion*, vol. 18, no. 2, pp.245 – 251, June 2003.
- [2] M. Florkowski and J. Furgal, "Identification of winding faults in electric machines using a high frequency method," *IEEE International Conference on Electric Machines and Drives*, Antalya, pp. 590 - 595, 2007.
- [3] B. Mehdi, S. N. Mohammad, B. Trevor and P. Toan, "FRA vs. short circuit impedance measurement in detection of mechanical defects within large power transformer," *IEEE International Symposium on Electrical Insulation (ISEI)*, Australia, 2012.
- [4] P. J. De Klerk and J. P. Reynders, "Winding Slackness Monitoring as a Diagnostic for Insulation Aging in Oil-paper Insulated Power Transformers", *11<sup>th</sup> International Symposium on High Voltage Engineering*. London: IET, pp 185 – 188, 1999.
- [5] L. Bolduc, P. Picher, G. Pare, R. Demers and J. Belanger, "Transformer Winding Displacement by the Frequency Response of Stray Losses (FRSL)", *CIGRE*, 2000.
- [6] J. Aubin and L. Bolduc, "Determination of Transformer Winding Displacement by FRSL Diagnostic Method", *Final Report on CEA Project, RP 77-47*. Paris, France, 1981.
- [7] N. Trinh, L. Bolduc and J. Aubin, "Dielectric and Short-Circuit Tests of Used Transformers", in *CEA Fall Meeting Electrical Apparatus Section.*, Winnipeg, 1983.



- [8] Hori Y. and Fujisawa F. "Electromechanical Coupling Vibration of Power Transformer under Short Circuit Conditions", *Transactions of the Japan Society of Mechanical Engineers Series C* - Japan: J-STAGE, 1993. - Vol. 59 no 563. - pp. 1993 - 1998. - 1884-8354.
- [9] M. Bagheri, M. Naderi and T. Blackburn, "Advanced transformer winding deformation diagnosis: moving from off-line to on-line", *IEEE Trans. on Dielectrics and Electrical Insulation*, vol. 19, no. 6, pp. 1860 - 1870, December 2012.
- [10] Chenguo, Yao; Zhongyong, Zhao; Yu, Chen; Xiaozhen, Zhao; Zhaojiong, Li, "Transformer winding deformation diagnostic system using online high frequency signal injection by capacitive coupling", *IEEE Trans. on Dielectrics and Electrical Insulation*, vol. 21, no. 4, pp. 1486 -1492, 04 September 2015.
- [11] Wang, M., and A.J. Vandermaar. "Condition Monitoring Of Transformers In Service By The Low Voltage Impulse Test Method", *High Voltage Engineering Symposium*. Canada, pp. 22-27, August, 1999.
- [12] F. Marek and F. Jakub, "Detection of winding faults in electrical machines using the frequency response analysis method", *Institute of Physics Publishing*, pp. 2067–2074, 5 July 2004.
- [13] G.-L. Eduardo, A. Guillermo and P. Jorge, "Non-invasive monitoring of transformers using the frequency response from controlled transient signals", *Ingenieria y Competitividad*, vol. 15, no. 2, pp. 23-33, September 2013.
- [14] A. P. Akshay and B. Parekh, "Sweep Frequency Response Analysis (SFRA)-An Approach to Detect Hidden Transformer Faults", *International Journal of Advanced Research in Electrical, Electronics and Instrumentation Engineering*, vol. 2, no. 5, pp. 1893 - 1896, May 2013.
- [15] G. L. Eduardo, A. M. Guillermo and G.-G. Carlos, "Current Status and Future Trends in Frequency-Response Analysis With a Transformer in Service", *IEEE Trans. On Power Delivery*, vol. 28, no. 2, pp. 1024-1031, April 2013.
- [16] E. Gomez-Luna, G. Aponte, W. Herrera and J. Pleite, "Experimentally obtaining on-line FRA in transformers by injecting controlled pulses", *Ingenieria e Investigacion*, vol. 33, no. 1, pp. 1-10, April 2013.
- [17] F. S. Sellschopp, A. Marco and L. Arjona, "An Automated System for Frequency Response Analysis With Application to an Undergraduate Laboratory of Electrical Machines", *IEEE Trans. on Education*, vol. 47, no. 1, pp. 57-64, February 2004.
- [18] Singh, A. "High frequency simulation of transformer windings for diagnostic tests". Thesis, Electrical Engineering, The University of British Columbia, Vancouver Campus: UBC Library, 2006.
- [19] S. Tenbohlen and S. A. Ryder, "Making Frequency Response Analysis Measurements: A Comparison of the Swept Frequency and Low Voltage Impulse Methods", *13<sup>th</sup> International Symposium on High Voltage Engineering*, pp. 25-29, August 2003.
- [20] Kraetge, A., M. Velasquez, J. L. Kruger, H. Viljoen, and A. Dierks. "Aspects of the Practical Application of Sweep Frequency Response Analysis", *6<sup>th</sup> Southern Africa Regional Conference*. Paris: CIGRE, pp. 2-10, 2009.
- [21] M. K. Ilampooman and M. Vikash, "Transformer Fault Detection by Frequency Response Analysis", *IOSR Journal of Electrical and Electronics Engineering*, vol. 1, no. 4, pp. 27-32, July-Aug. 2012.
- [22] Maximilian, Heindi, Tenbohlen Stefan, Velasquez Juan, Kraetge Alexander, and Wimmer Rene. "Transformer Modelling Based On Frequency Response Measurements For Winding Failure Detection", *Proceedings of the 2010 International Conference on Condition Monitoring and Diagnosis*. Tokyo, Japan: Institute of Electrical Engineers of Japan, pp. 201-204, 2010.
- [23] A. Kraetge, M. Kruger, J. L. Velasquez, H. Viljoen and A. Dierks, "Aspects of the Practical Application of Sweep Frequency Response Analysis," in *6<sup>th</sup> Southern Africa Regional Conference, CIGRE.*, 2009
- [24] Larry, Coffeen, Britton Jeffrey, and Rickmann Johannes. "A new technique to detect winding displacement in power transformers using frequency response analysis", *IEEE Bologna Power Tech Conference*. Bologna Italy, pp. 2-7, 2003.
- [25] R. Samsudin, H. S. Yogendra and Y. Zaidey, "Detection of Near Failure Winding due to Deformation in 33/11 kV Power Transformer by using Low Voltage Impulse (LVI) Test Method and Validated through Untanking", *International Journal of Mechanical, Aerospace, Industrial, Mechatronic and Manufacturing Engineering*, vol. 4, no. 12, pp. 430-435, 2010.
- [26] M. Forlovski, "Exploitation stress and chalanges in diagnostics of industrial equipment", *IEEE International Symposium on Industrial Electronics*, pp. 15-25, 2011



**Nnachi Gideon** was born in Afikpo Nigeria on September 27, 1982. He received the B.Eng degree in Electrical Engineering from Nnamdi Azikiwe University Awka, Nigeria in 2013. He is currently an M.Sc Student of Electrical Engineering (Power System) at French South African Institute of Technology (F'SATI) and an M.Tech Research Student in the same department at Tshwane University of Technology, Pretoria-South Africa.



**Dan Valentin Nicolae**, born in Romania 18/09/1948, has got his first degree Master in (Applied) Electronic Engineering in 1971 from University Polytechnic of Bucharest, Romania. Between 1971 and 1975 he was with Institute for Nuclear Technologies as design engineer, than in 1975 he joined National Institute for Scientific and Technical Creativity – Avionics Branch in Bucharest Romania as principal researcher.

In 1998, DV Nicolae joined Tshwane University of Technology as lecturer for heavy current subjects. In 2000 he started his research activity in TUT with a stage in France; with this opportunity he started his PhD which has been finalized in 2004. In 2015 he joined University of Johannesburg. Presently, Prof. DV Nicolae is involved in research in power converters for power systems and electric machines.