

MODELLING AND ANALYSIS OF RMS-DC SOLID STATE THERMAL CONVERTER

¹⁾ Mmatselagale M. Hlakola, ¹⁾ Dan V. Nicolae, ²⁾ Eugene Golovins

1) Electrical and Electronic Engineering Technology Department, University of Johannesburg
South Africa

2) National Metrology Institute of South Africa
Pretoria, South Africa

mhlakola@nmisa.org, dnicolae@uj.ac.za, egolovins@nmisa.org

ABSTRACT

The Root Mean Square (RMS) measurements of alternating signal are frequently done by means of thermal transfer instruments. The principle of these thermal transfer instruments is to transfer the heating energy of resistive load to a temperature-sensing element. The DC output of the sensor gauges the amount of electrical power (AC or DC) applied to the input. The paper examines performance of an RMS-DC thermal converter of a solid state technology type at various frequencies such as LT1088CD integrated circuit. The theoretical and simulation analysis is carried out to outline the factors influencing the transfer characteristics of the converter device in the DC and AC input regimes.

KEY WORDS

Thermal converter, Thermoelectric sensor, Thermal transfer, Solid state device.

1. Introduction

The transfer methods based on the use of thermal converters in the National Metrology Institutes (NMIs) were developed by Hermach [1]. The classic thermal converter is made of a heater resistance and a thermo-sensor in thermal contact with the heater but isolated electrically and is commonly known as a single-junction thermal converter (SJTC). Recently, multi-junction thermal converters (MJTCs), thin-film (planar) MJTC and semiconductor (solid state) RMS sensors have been developed and implemented as AC-DC transfer standards. The modifications were made by adding more thermal junctions (thermocouples connected in series, around a common heater) to the SJTC, which led to the evolution into a MJTC. The disadvantages of the MJTC originate from its fabrication complexity. Then these standards were further modified by laying the heater resistor and thermocouples metal on thin-film technology on the silicon wafer [1]. The evolution of thin-film planar MJTCs is in the process of active research. The most commercial solid-state thermal transfer standards have thermal converters based on transistor/diode sensors [2],[3].

Further, in this paper, the basic principle of thermal RMS converter with mathematical approach is presented in

section 2. Section 3 presents the simplified diagram of a “single-junction” diode-base thermal converter.

2. Theoretical background

2.1. Principles of AC-DC conversion

The RMS of an AC signal and the equivalent DC signal applied to the input should generate the same output in a perfect device. The RMS value assigned to an AC signal is the amount of the DC signal required to produce equivalent amount of heat on the same load. In accordance to the RMS definition, the AC signal is compared with the DC signal by alternately applying them to the same heater and measuring the temperature rise. Mathematically, it involves squaring the signal, taking the average and obtaining the square root. For any form of voltage signal $v(t)$, the basic definition of the true RMS conversion is [4], [5]:

$$V_{RMS} = \sqrt{\frac{1}{T} \int_0^T v^2(t) dt} \quad (1)$$

Based on this definition a few solutions exist at present:

- Rectification and scaling that is mostly applied for periodic sinusoidal signals.
- Analog integrator circuit where the integration depend on an additional capacitor. Hence it has problems for low frequencies as well as for high frequencies.
- Thermal AC-DC converter – as studied in this paper.

2.2. Principle of thermal RMS

Figure 1 shows the basic principle of a thermal converter. The method compares the heating response of an unknown AC signal to the heating response of a known DC reference, which is calibrated in the laboratory to an SI-traceable standard. Under the condition of the perfectly matched heater-sensor pairs R_1-S_1 and R_2-S_2 , The power dissipated by the temperature sensing elements S_1 and S_2 will be equivalent when the calibrated voltage reference is adjusted to null the temperature difference between the reference resistor (R_2) and the input signal resistor (R_1). Basically, by the definition of the RMS, the DC reference

voltage will be equal to the RMS value of the unknown AC signal voltage [5].

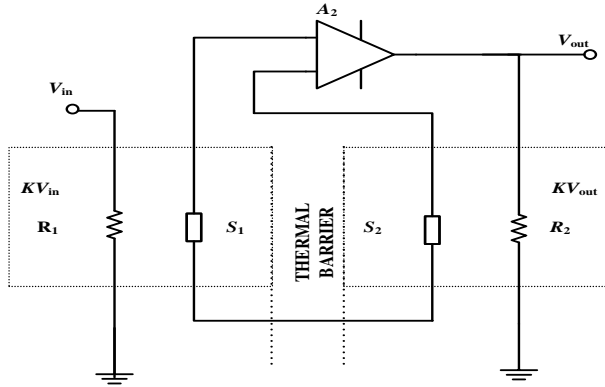

Figure 1: Thermal RMS conversion – basic principle

The thermal conversion units, which are designed for direct AC voltage measurement, consist of stable resistors (R_1 and R_2) having low temperature coefficient, which are in thermal contact with linear temperature-to-voltage converters (S_1 and S_2). These could be thermistors, diodes or bipolar junction transistor. The RMS-DC thermal converter has a very low error (less than 0.1%) and a wide bandwidth. The fixed time constant of the thermal components (R_1 , S_1 , R_2 and S_2) degrades the low frequency effectiveness of the RMS computational circuit [5]. This design approach provides a DC output related to the RMS input with very good linearity over a wide input range in voltage and frequency. The input-to-reference differential amplifier feedback sets balance between the matched heater-sensor pairs and thus ensures linearity relating output to the RMS value of the input.

2.3. Mathematic modelling of the thermal converter

The input signal into the first heater (R_1) is converted into heat/temperature (θ) at each instant as [1]:

$$R_1 \cdot i_1^2 = k_1 \cdot \theta_1 + M_1 \cdot \frac{d\theta_1}{dt} \quad (2)$$

Where, R_1 , k_1 and M_1 are parameters which in general depend on the temperature rise θ . If the thermal inertia is high enough so that θ is essentially constant during the cycle then the steady-state temperature rise is simply [1]:

$$\theta_1 = \frac{I_1^2 \cdot R_1}{k_1} \quad (3)$$

Where, I_1^2 is the squared RMS value of the input current. The temperature rise is thus the true measure of the RMS current even if R_1 and k_1 are temperature dependent [1]. Same logic must be applied for the second part of the thermal converter:

$$\theta_2 = \frac{I_2^2 \cdot R_2}{k_2} \quad (4)$$

Where, I_2^2 is the square of the DC output current. Because the two thermal sensors are included in the feedback of a differential amplifier that keeps θ_1 and θ_2 equal and by design and construction all the other parameters are equal, then the output DC current is equal to the RMS value of the AC input current:

$$I_{2-DC} = I_{1-RMS} \quad (5)$$

2.4. Errors affecting thermal converter

There are many causes for AC-DC transfer difference:

- The main source of errors is mismatching of parameters of the two sections of the device.
- One other source of errors could be the thermal coupling between the sections. The entire derivation is based on presumption of the two sections being two adiabatic systems meaning no heat exchange between them.
- Thermoelectric effect (DC offset): passing of the DC signal through the heater of an RMS-DC thermal converter results in non-joule heating/cooling due to Thomson and Peltier effects. This produces a frequency-independent offset in the AC-DC difference [6].
- High-frequency characteristic: The significance of the skin and proximity effects is observed at high frequencies, the alternating signal is confined to surface regions of the heater and not distributed uniformly across it. Therefore, the reactive components of the heater influence power dissipation within it when it is carrying a high-frequency alternating signal [6], [7].
- Low-frequency characteristic: double-frequency thermal ripple is expected at the output of the RMS-DC thermal converter [6], [7].

2.5. Definition of the AC-DC difference of the thermal converter

The AC-DC difference of a thermal converter is defined by equation (6):

$$\sigma_x = \frac{Q_{AC} - Q_{DC}}{Q_{DC}} \quad (6)$$

Where, Q_{AC} is an RMS AC quantity (voltage or current) and Q_{DC} is a DC quantity which produces the same output response as the RMS AC quantity [8], [9].

3. Matlab modelling, simulation and results

3.1 Simulation model architecture

The heater-sensor network diagram is shown in Figure 2 built in Matlab platform. The heater-sensor network uses the resistor block with an exposed thermal port to model a temperature-dependent resistor.

Figure 3 shows the Matlab simulation model of the RMS-DC solid state thermal converter. The model design

assumes that the electrical input-output leakage (i.e. common mode noise) is absent. Since the technology of the matched pair of the thermos-resistive sensing elements is implemented inside the standard integrated circuit (IC) package, the state-of-the-art principles of the thermal effect modelling are applied to describe the heat transfer between the heater metal and semiconductor diode.

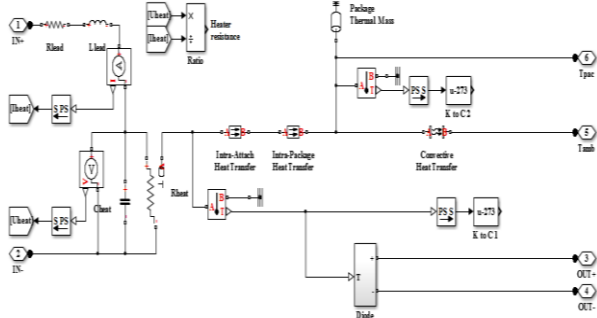

Figure 2: Heater-sensor network diagram

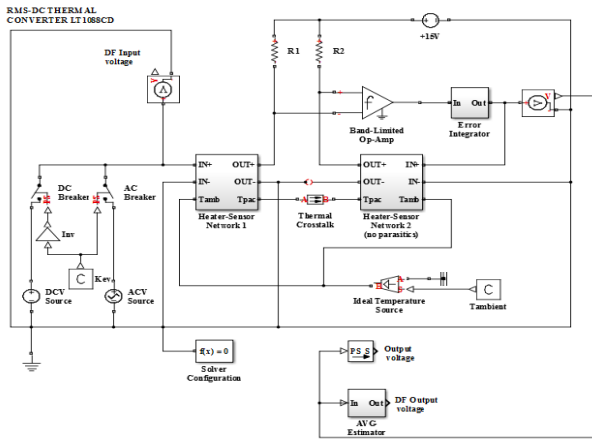

Figure 3: Simscape simulation model of RMS-DC solid state thermal converter

3.2. Simulation model parameters

The realised model capitalises on the electrical and thermal parameters extracted from the LT1088CD datasheet [10]. The heater is the resistor with the known temperature coefficient ($\alpha = 0.002$ 1/K that identifies heater metal as brass having thermal conductivity 109 W/(m·K), specific heat capacity 380 J/(kg·K) and density 8500 kg/m³) that shares the die hosting the sensing diode(s) [11]. The thermal resistor parameters are determined using the thermal equilibrium (steady state) equality under the maximum input power [12]

The thermal sensor die is modeled as silicon due to both higher thermal conductivity (130 W/(m·K)) and higher specific heat capacity of 700 J/(kg·K) that yields larger thermal time constant. The diode junction is microscopic and has no thermal mass; thus the assumption holds that it gets heated immediately when the heat flux reaches it. The diode is a non-linear thermos-resistive element, and

resistances of the metal lead tracks, which terminate at the diode pads and carry direct current, do not depend on the die temperature fluctuations, i.e. they can be excluded from the thermal network model. The low-temperature co-fired ceramics (LTCC) or glass-ceramics are used to package the two heater-sensor of the model - to prevent thermal cross-coupling between the sensor dies and minimise thermal exchange with the ambient [11]. The die is isolated by vacuum or air from the package walls to provide the best thermal resistance and thus prevent heat flux losses [13]. The air impregnated polymer layer is used to attach the die to the cavity bottom. This layer has a relatively high thermal resistance [11].

3.3. Performance results

The first set of simulation was to validate the frequency response and the heater-sensor temperature. Figure 4 shows the behaviour of the RMS-DC solid state thermal converter at the DC mode. Figures 5, 6 and 7 show the response for a sinusoidal 3 V_{RMS-IN} at 10 Hz, 50 Hz and 100 Hz respectively.

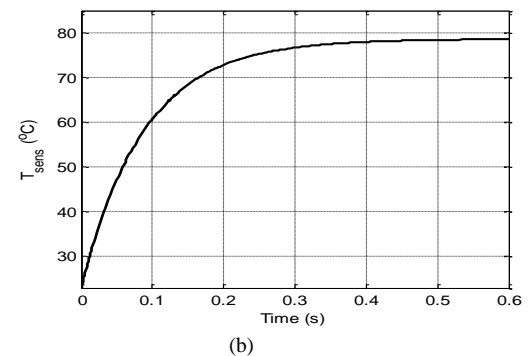
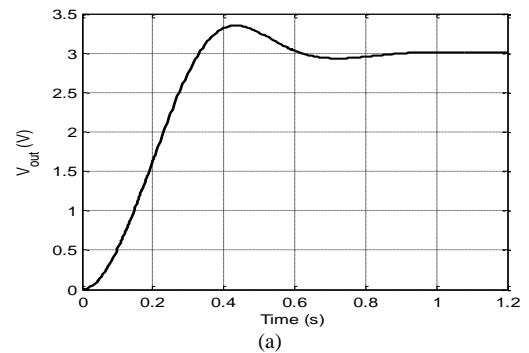
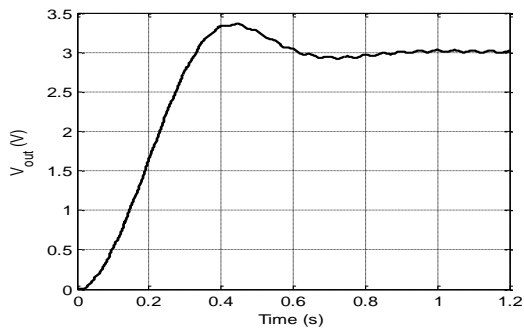
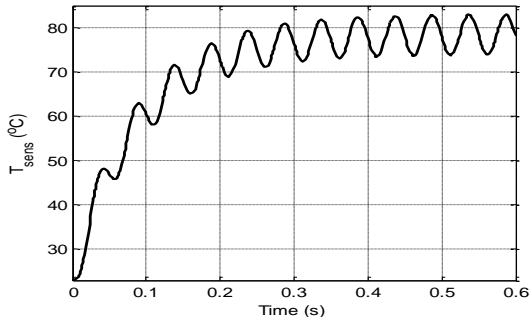

Figure 4: DC response of the RMS-DC solid state thermal converter (a) Output voltage, (b) Heater temperature



(a)



(b)

Figure 5: 10 Hz response of the RMS-DC solid state thermal converter, (a) Output voltage, (b) Heater temperature

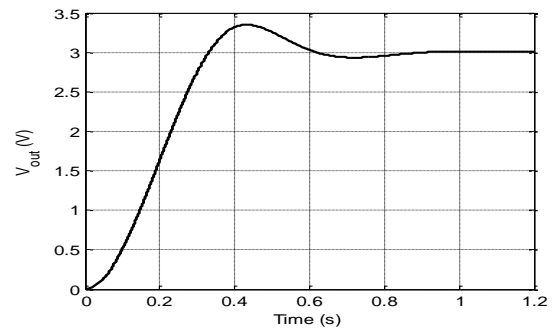

(a)

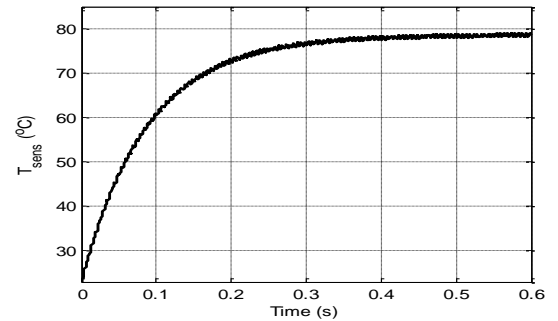

(b)

Figure 7: 100 Hz response of the RMS-DC solid state thermal converter (a) Output voltage, (b) Heater temperature

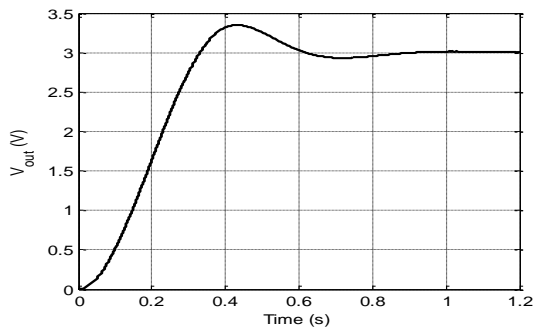

(a)

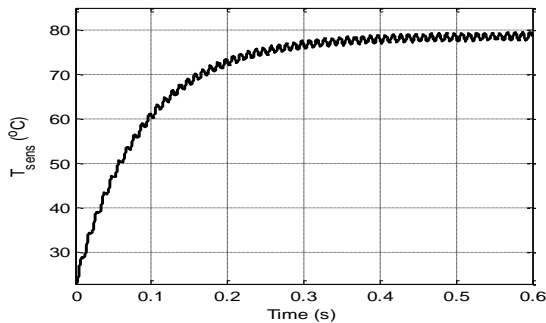

(b)

Figure 6: 50 Hz response of the RMS-DC solid state thermal converter, (a) Output voltage, (b) Heater temperature

The simulation results analyze the frequency response and heater temperature of the RMS-DC solid state thermal converter. The converter under study settles to a valid voltage output very quickly with negligible drift when compared to a thermocouple-based converter. The transient thermoelectric effects are observed by the ripple of the output voltage before settling to a constant value. The fast settling output voltage is produced by the small physical size of the RMS sensor, and the close matching of the two sections of the chip and the error integrator at the output of the thermal converter.

When a DC signal is applied to the input of the heater, the heater of the RMS-DC solid state thermal converter reaches a constant temperature. When an AC signal (sinusoidal voltage) of frequency f is applied to the RMS-DC solid state thermal converter, joule heating in the thermal network varies with a double frequency, $2f$ [6], [14]. The temperature of the heater varies cyclically around the mean value, with amplitude which decreases with an increasing input frequency.

Provided that the input signal and the thermal network output are directly proportional to each other, the true RMS value of the AC signal can be determined by equating the mean of the varying heater temperature to the constant voltage of the DC reference. Nonlinearities in the direct proportional relationship will result in errors in the RMS value, i.e. the greater the nonlinearities the larger the errors. Any slight departure from the direct relationship of the input signal and output signal will have

a slight effect on the AC-DC transfer difference when the double frequency thermal ripple is small. The reactive components of the heater influence how the signal is dissipated within it when it is carrying a high-frequency AC signal. The described responses depend on conditions that must be realized while the RMS-DC converter is designed.

The second set of simulation was to validate the true RMS-DC conversion of the RMS-DC solid state thermal converter. Figure 8 shows the response of the 3 V_{RMS-IN} square wave and the sinusoidal wave signals at 50 Hz

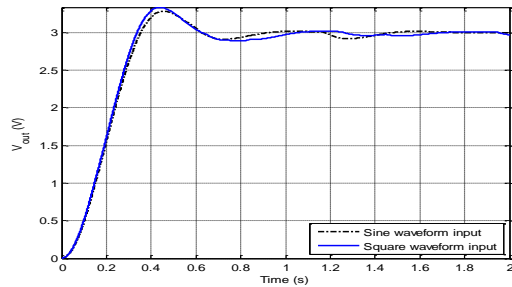

Figure 8: 50 Hz response of the RMS-DC solid state thermal converter for sinusoidal and square waveform input

It is observed that the RMS-DC solid state thermal converter maintains the same response for both the sinusoidal and square waveforms input. Thus, the RMS-DC solid state thermal converter provides true RMS-DC conversion regardless of the input waveform.

Figure 9 shows the plot of the linearity error of the RMS-DC solid state thermal converter, where:

$$\text{Linearity error} = \left| \frac{V_{in} - V_{out}}{(V_{in})_{max}} \right| \times 100\% \quad (7)$$

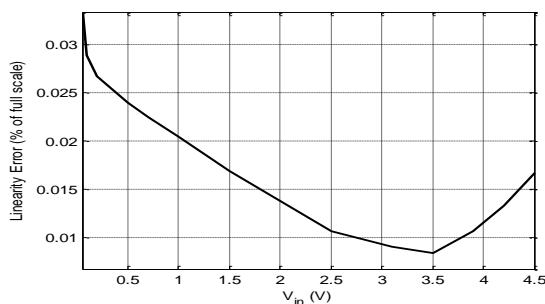

Figure 9: Linearity error of the RMS - DC solid state thermal converter: 0 V - 4.5 V

It is observed that the error due to nonlinearities in the RMS-DC solid state thermal converter is very small. Thus, the temperature rise of the heater can be used to accurately measure the RMS alternating signal

In the determinations of the AC-DC transfer difference of the RMS-DC solid state thermal converter at higher frequencies, the skin effect of the heater, the stray inductance and capacitance at the device input are significant. Based on the definition of the AC-DC transfer difference, the AC and DC voltage are compared by the thermal method. Figure 10 shows the input and output AC-DC difference of the RMS-DC solid state thermal converter at higher frequencies.

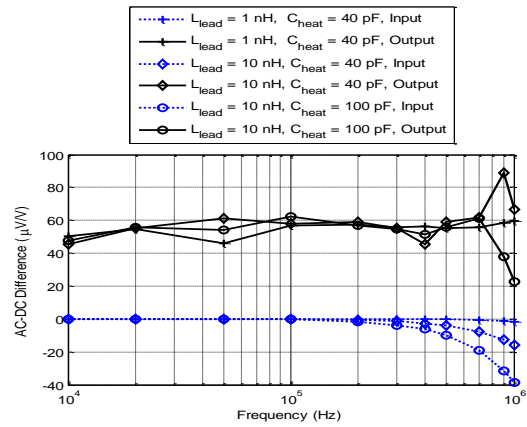

Figure 10: The input and output AC-DC transfer difference of the RMS-DC solid state thermal converter

When equal amount of AC and DC voltage is applied to the input heater of the thermal converter, the output response is expected to be equal for both inputs. However, due to the effect of non-joule heating and frequency characteristics of the heater of the thermal converter, the difference is observed between the output responses. The AC or DC signal can be adjusted in order to obtain the equal output response for both signals. The RMS-DC solid state thermal converter has negative AC-DC transfer difference at the input, which signifies that a large amount of DC than AC is required by the RMS-DC solid state thermal converter to operate at the same output level for both AC and DC signals.

5. Conclusion

In this paper an RMS-DC solid state thermal converter based on matched pair diodes and heaters has been analysed and modelled. It was simulated at various frequencies and the results were presented and discussed. The analysis carried out in the paper outlines different factors which the errors affecting a thermal converter under calibration depend on.

Mathematic modelling was developed for better description of the thermal RMS converter operation and performances. The solid-state thermal converter offers many advantages such as short time constant and better frequency response compared to thermocouple-based thermal converters, Furthermore the solid-state thermal converter possesses linear input-output response, hence,

the solid-state thermal RMS sensor is a practical alternative to single and multi-junction Thermal Voltage Conversions in all AC-DC difference applications.

Acknowledgements

The support and guidance from Prof. D.V. Nicolae and Dr. E. Golovins is greatly appreciated. The financial assistance from National Research Foundation (NRF) is greatly acknowledged. Special thanks to the NMISA DCLF and RF committee for their endless support and the opportunity to conduct my research at the institution.

References

- [1] L.F Hermach, AC-DC comparators for audio-frequency current and voltage measurements of high accuracy, A Survey of AC-DC Transfer Instruments and Basic Standards, *IEEE Trans. Instrum. Measure, IM-25*, pp. 489-496. Dec. 1976
- [2] L.L. Szepesi, Recent developments on solid-state thermal voltage converters, *Proc. Measurement Science Conference*, Irvine, CA, pp. 9-13, 22-23 January, 1986
- [3] M. Klonz, Current developments in accurate AC-DC transfer measurements, *IEEE Transactions on Instrumentation and Measurement*, Vol.44, No.2, April 1995
- [4] <http://www.npl.co.uk/measurement-services/DC-LF/AC-DC-voltage-and-current-transfer>
- [5] C. Kitchin and L. Counts, RMS-DC conversion, (*Application guide*, 2ND Edition, Section 1, pp 2-3, 1986)
- [6] Nano-Electronics Research Institute/AIST, Japan, A guide for establishing primary AC-DC transfer, *Tentative Version 2.01*, pp. 10-20, 12/April/2007
- [7] F.J, Wilkins, Theoretical analysis of the AC-DC transfer difference of NPL multi-junction thermal converter over the frequency range DC to 100 kHz, *IEEE Trans. Instrum. Meas.*, vol. IM-21, pp. 334-340, Nov. 1972
- [8] DCLF\U-0005, Procedure for calibration of AC-DC voltage transfer standards
- [9] Fluke, 792A AC/DC transfer standard, Instruction Manual, 1990.
- [10] LT1088- Wideband RMS-DC Converter Building Block. www.linear.com/docs/4087
- [11] J. Williams, A monolithic IC for 100 MHz RMS-DC conversion, (*Application Note 22*. AN22-4, September 1987.)
- [12] M. A. Davies, T.L Schmitz, System Dynamics for Mechanical Engineers (Chapter 9: Thermal Systems, pp 289-312, 2005)
- [13] Prof. Dr.-Ing. Jurgen Wilde, Lecture Notes for assembly and packaging technology, Laboratory for assembly and packaging technology, 2012
- [14] F.L. Hermach, Thermal converters as AC-DC transfer standards for current and voltage measurements at audio frequencies, *Journal of Research of the National Bureau of Standards, Research Paper*, Vol.48, 2296, No.2, February 1952