

PV and Arduino based water temperature control system

*N.E Mabunda, **M.K Joseph,

*,** University of Johannesburg

This paper discusses how Arduino and Photo Voltaic (PV) can be used to manage geyser water temperature. National grid power is used to raise the water temperature level from its minimum value to a maximum temperature of 50 °C as determined by the geyser thermostat. Once the water temperature is at 50 °C the Arduino's software will switch the power source to a solar, which will then raise the water temperature further to a maximum of 72.5 °C as determined by the installed thermocouple. The solar source consists of an installed 50 W solar panel, charge controller, solar battery, Thermoelectric Generators (TG) and a 600 W modified sine wave DC to AC inverter.

Index Terms: PV, energy recycling, water temperature

I. INTRODUCTION

PV is amongst the favored alternative sources of energy that can be used without further damage to the atmosphere and runs at lower costs. An element geyser is one of the domestic equipment that uses more electrical energy than other appliances in the house. The use of solar for heating appliances such as geysers will result in a significant drop of electricity usage as suggested in [1]. Batteries don't have enough capacity to run geysers and PV energy is only available during the day but not always, as a result it is common to find geysers that are powered by non-renewable energy sources. Various methods to save energy consumption by geysers have been studied and implemented. The simplest technique being to keep the geyser off when warm water is not required as discussed in [2]. In [3] A PIC in micro controller was used to create geyser usage profile for individuals and later controls geyser water temperature based on this usage profile so as to optimize energy consumption by the geysers. Smart unit to monitor geysers environmental variables such as temperature and power consumption and switch off on the geyser has also been developed [4]. A simplified model of a wind and solar powered geyser that heat water to a temperature of 40 °C has been presented in order to justify feasibility [5]. In this paper we discuss the application of how PV and Arduino micro controller can be used to maintain geyser water temperature and therefore save electrical energy consumption.

A. Objectives

The main objective is to use PV and Arduino micro controller to control geyser water temperature.

The sub-objectives are:

- To develop a prototype of hybrid water heating unit that will be powered by both PV and national grid power.
- To use TG to recycle energy that is wasted in a form of heat.

II. TEMPERATURE CONTROLLER SYSTEM LAYOUT

A. Hardware components

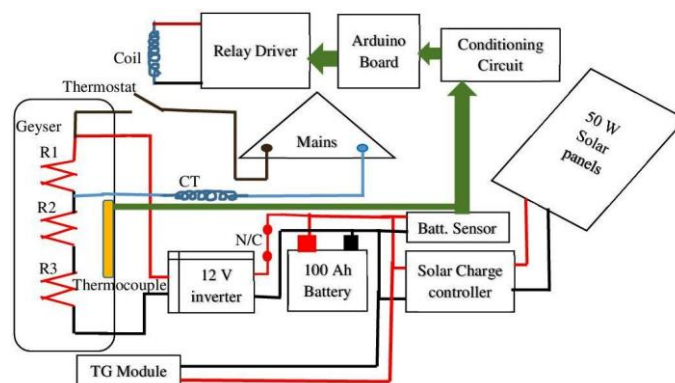

Figure 1. Temperature control system.

The system is designed to use an existing thermostat to preset the desired highest water temperature limit when heated by the original 50 Ω geyser element presented in Figure 1 as R1. Two additional 50 Ω elements R2 and R3 are added to R1 forming a series circuit with the total resistance of 150 Ω . The mains voltage is applied across R1 whilst the renewable energy voltage is applied across the total series resistor chain that consists of R1, R2 and R3. The total power given by each source can be calculated by using the equation:

$$P = V^2 / R \quad (1)$$

The total power applied by the mains to R1 will therefore be

$(P_m) = (230 \text{ V})^2 / 50\Omega = 1058 \text{ Watts}$. The total power supplied from the DC – AC inverter to R1, R2 and R3,

$(Pr) = (230 \text{ V})^2 / 150\Omega = 353 \text{ Watts}$. A thermocouple is installed to sense water temperature and then supply its output voltage via conditioning circuit to the Arduino controlling circuitry. A 50 W solar panel collects solar energy and feed it to a 10 A charge controller which will then supply the battery with a properly controlled charging current. TG module based 12 V battery charger similar to the one in [6] is included to assist with the recycling wasted heat energy back to the battery. The battery is used to power a 12 V DC – AC inverter that gives an output rms voltage of 230 V. Based on the system configuration illustrated in Figure 1 and see the software algorithm in fig 2.

B.Arduino software code

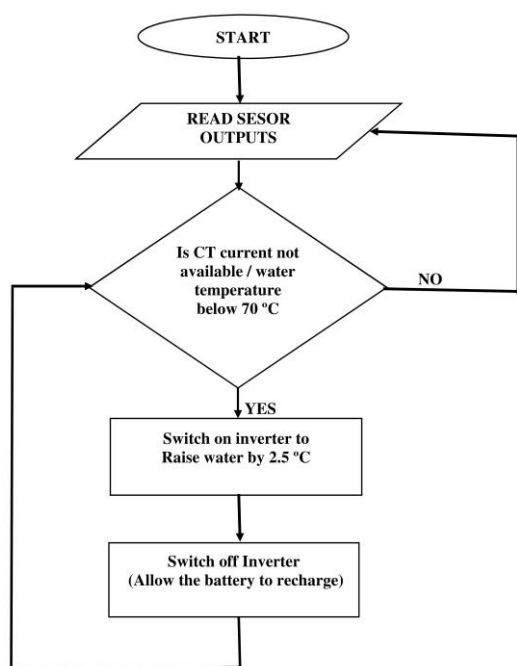

Figure 2. Arduino software code

The algorithm is illustrated in Figure 2. This system will use national grid power to heat water up to the temperature determined by the thermostat, instead of switching off the geyser element, the renewable energy devices will further increase the water temperature every three hours by 2.5 °C and stop when the water temperature of more than 70 °C is detected by an installed thermocouple. In the absence of national grid power and water usage, the unit on its own will be able raise water temperature from minimum to a maximum permissible temperature within two to four days, and there after uses less energy to keep the water temperature at the highest point. Therefore this unit can also be used purely from renewable energy provided that hot water usage optimized or renewable energy capacity is increased. It therefore also works as hybrid geyser.

Figure 2 illustrates the controlling program found in the Arduino board. The Arduino will start by acquiring sensor values which are applied to its Analog to digital convertors. For further information regarding this board refer to [8]. If the geyser thermostat is switched on, the geyser will then use the national grid power and the inverter will be disconnected until the water temperature rise to 50 °C where the geyser thermostat cut off the CT (Current Transformer) current. When the CT current is no longer available, the software will progress to check if the thermocouple temperature reading is below 70 °C, at a first run the temperature will be about 50 °C. An inverter will then be switched on to raise the water temperature by 2.5 °C and there after switched off in order to allow batteries to recharge. After battery recharging the water temperature will be checked again to determine the necessity of repeating water heating and battery charging process. The battery charging and water heating process will only stop when water temperature falls in a range between 70 °C and 72.5 °C. To calculate battery charge time, the water heating time in hours must first be calculated by using the formula found in [9].

$$P = \text{Energy (J)} / \text{Time (s)} = (c \times m \times \Delta T) / t \quad (2)$$

$$\text{Heating time will be:} \quad = 0.208125 \text{ h}$$

Assuming 80 % efficiency for the inverter as listed in [7], then battery current $I = 1.2 \times 350 \text{ Watts} / 12\text{V} = 35 \text{ Amps}$. Also assuming the average charge current of 3 A, charging time (t) will then be $= 35 \text{ A} \times 0.208125 \text{ h} / 3 \text{ A} = 2.428 \text{ h}$. Therefore the total charging and discharge time $= 2.428\text{h} + 0.208125 \text{ h}$. According to [8] geyser water temperature will drop by 0.42 °C per hour, therefore if water is not being used; on average water temperature will rise by 1.7 °C per hour.

III. TEST METHODOLOGY

In order to minimize cost the selection of test apparatus will be based on both cost and the availability. Table 1 list component names, function and the reason for selection. Also the hardware and software tests will be conducted separately.

TABLE 1: List of test apparatus

Apparatus	Function	Reason
350W inverter	Replace 400W Inverter	Available
3 X 80 W bulbs	Used to visualize heaters	Cheap
3 X 50 Ω elements	Used to heat Water	Cheap
50 W Solar panel	Charge 33 Ah battery	Available
12 V 30 A relay	Switch on off inverter	Available
33 Ah Battery	Power an 80 W bulb	Available
Temp. probe	Replace thermocouple	Cheap
Thermometer	Measure water temperature	Cheap
Power switch	Represent thermostat	Cheap
Arduino board	Test software	Available
6 LED	Indicate geyser actions	Cheap
TG module	Represent TG charges	Cheap
25 l water bucket	Represents geyser	Cheap

A. Hardware test

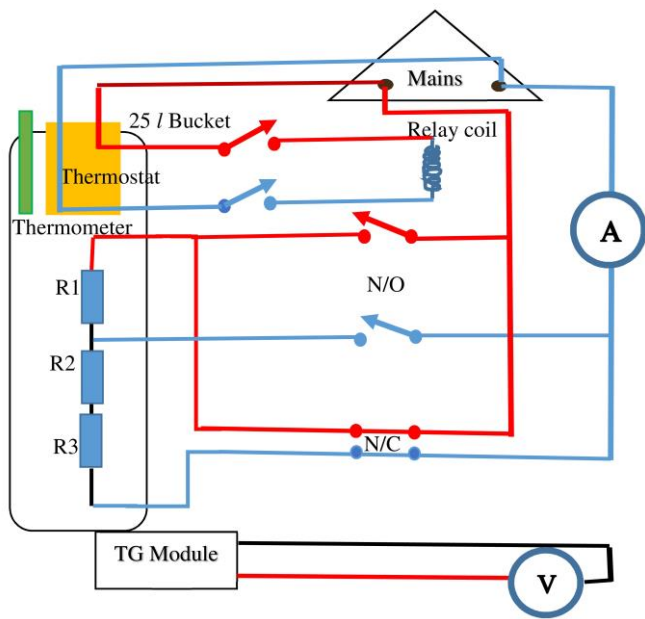

Figure 3: Wiring diagram for hardware testing

Figure 3 represents equipment connections for testing the hardware. Solar panel, battery and inverter were all substituted by the 230 V mains power which is connected through the normally closed relay switch to the slow heating element represented by R₁ R₂ and R₃. The testing was conducted as follows: A 25 litre water bucket was filled up with cold tap water and the system was powered on. A normally closed thermostats energized the relay coil which then enabled the normally opened switch section to power on the fast heating element represented by R₁. The thermostats that was set to 60 °C kept R₁ on for about 20 minutes before it is switched off when the water temperature reached 59.3 °C. During the first 20 minutes the total power was calculated by using ammeter current reading and a known AC voltage of 230 V, immediately when the thermostat goes off, the normally closed section was activated to switch on the slow heating element. This element was then left to run for 9 minutes with a total calculated power of 334 Watts. The system was then switched off and the water was allowed to cool down for 9 minutes. The thermionic generator open circuit voltage was also recorded from the connected voltmeter.

IV. RESULTS AND DISCUSSIONS

A. Hardware performance

TABLE 2: Hardware test results

Thermostat set to 60 °C			
National Grid Voltage =2 30 V			
Time	TGVoltage (mV)	Water Temperature (°C)	Input Curret (A))
18:37	46.9	25.5	4.75
18:42	22.7	34.3	4.75
18:46	26.9	41	4.75
18:51	36.2	49.1	4.75
18:56	4.01	57.1	4.75
18:57	78.5	59.3	1.32
19:03	35.5	60	1.32
19:04	0.14	60.1	1.32
19:05	-1.6	60.2	1.32
19:06	0	60.3	1.32
19:07	1.3	60.4	1.32
19:08	-2.5	60.5	1.32
19:09	-1.4	60.6	1.32
19:10	-4.5	60.7	1.32
19:11	-4.7	60.8	1.32
19:12	-4.5	60.7	0
19:13	-4.7	60.4	0
19:14	-4.6	60.2	0
19:15	-0.42	60.1	0
19:16	-4.2	60	0
19:17	-3.5	59.8	0
19:18	-3.2	59.7	0
19:19	-2	59.5	0
19:20	-2.1	59.4	0
19:21	4.7	59.3	0

Table 2 clearly demonstrate that it took fast heating element 20 minutes to raise water temperature from 25 °C to 60 °C. After that the slow heating element set representing solar based heating element further raised water temperature by 1.5 °C within 10 more minutes. It is also shown that it has taken another 10 minutes for the water to cool down to a thermostat set value of 60 °C. Overall the in this instance renewable energy was used to double the time it takes for the thermostat to restart. Refer to figure 4 to see how constant temperature of about 60 °C. Was maintained for 20 minutes instead of natural 10 minutes. Renewable energy will only double the time, but rather keep the thermostat off as long it is available and heated water is not replaced by new cold water.

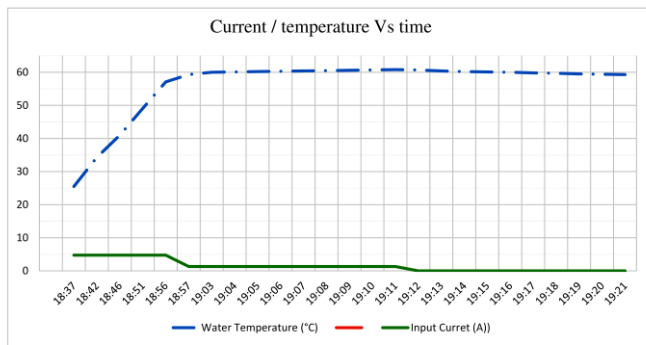

Figure 4: Geyser performance over time domain

The figure illustrates the geyser performance over time domain. As in Table 2 and Figure 4, between 19:03 and 19:12 hrs the temperature would have dropped to thermostat level.

V. CONCLUSIONS

In this paper we used a PV and Arduino micro controller to control geyser water temperature. We developed a prototype of hybrid water heating unit that will be powered by both PV and national grid power. We used TG to recycle energy that is wasted in a form of heat.

VI. ACKNOWLEDGEMENT

We are grateful to the National Research Foundation for funding this research.

VII. REFERENCES

- [1] T. A. Main and K. A. Folly, "Effects of tariffs and energy saving schemes on domestic households energy consumption," in AFRICON, 2013, Pointe-Aux-Piments, 2013.
- [2] Eskom, "Eskom Fact Sheet," 2016. [Online]. Available:http://www.eskom.co.za/sites/IDM/Documents/127581ESKD_Geyser_Fact_Sheet.pdf. [Accessed 12 April 2016].
- [3] Q. Catherine, J. Wheeler, R. Wilkinson and G. de Jager , "Hot water usage profiling to improve geyser efficiency," *Journal of Energy in Southern Africa* , vol. 23, no. 1 , pp. 39-45, 2012.

- [4] R. Hulsbos , C. P. Kruger, G. P. Hancke and R. M. dos Santos, "Design of a smart geyser controller unit," *in AFRICON* , Addis Ababa, 2015.
- [5] J. Braid, "Off-grid domestic water heating from solar and wind power: A feasibility study," *in AFRICON* , Addis Ababa, 2015.
- [6] M. Rahman and R. Shuttleworth, "Thermoelectric power generation for battery charging," *in Energy Management and Power Delivery*, 1995, Singapore, 1995.
- [7] Mean-well, "600W Modified Sine Wave DC-AC Power Inverter A-301/302-600 series," [Online]. Available: http://www.meanwell.com/mw_search/a300-600/A-301,302-600-spec.pdf. [Accessed 13 04 2016]
- [8] Arduino, "ARDUINO PRODUCTS > Arduino Yún," Arduino, [Online]. Available: <https://www.arduino.cc/en/Main/ArduinoBoardYun>. [Accessed 13 April 2016].
- [9] Q. Catherine, J. Wheeler, R. Wilkinson and G de Jager Hot water usage profiling to improve geyser efficiency, *Journal of Energy in Southern Africa* 23(1) 2012, pp.39-45