

LV Self Balancing Distribution Network Reconfiguration for Minimum Losses

D. V. Nicolae, M. W. Siti and A. A. Jimoh

Abstract-- The reconfiguration of the distribution network feeders can be defined as the restructuring of the feeders through the changing of the open/close states of the sectionalizing and tie switches. This creation of a new distribution network topology is normally required to improve the performance of the network, and thus sometimes the efficiency of the electricity supply. For optimum loss reduction, feeder reconfiguration is often considered as an option. This, however, requires the implementation of an appropriate switching control strategy. It would be desirable for the switching to be automatic, that is to follow the connected load situation of the feeder. The proposed optimal reconfiguration of the phase balancing using the heuristic method proves to be robust compared to neural network method, to turn ON and OFF the different switches, allowing the three phases supply of the transformer to the end-users to be balanced. This paper presents the application examples of the proposed method using the real data.

Index Terms-- distribution systems, phase balancing, static switches, neural network.

I. INTRODUCTION

There two types of switch in primary distribution systems: normally closed switch which connects line sections, and normally open switch on the tie- lines which connects two primary feeders, or two substations or loop-type laterals. Network reconfiguration (or feeder reconfiguration) is the process of altering the topological structures of the distribution feeders by changing the open/close status of the sectionalizing and tie switch [1]. During normal operating conditions, an important operation problem in configuration management is network reconfiguration. As operating conditions change, the main reasons to reconfigure a network are: 1) to reduce the system real power losses and 2) to relieve overloads in the network [1]. It can also be used for the networks reconfiguration management operation to restore service to as many customers as possible during a restorative state following a fault.

Many studies have been done in the past, [2-6] for the medium voltage, with the use of sectionalize switch and tie switch to achieve a better efficiency, but they did not guarantee the optimal solution although they provide high quality suboptimal solution. In this paper the focus will be on the low voltage phase balancing.

To reduce the unbalance current in a feeder the connection phases of some feeders are changed manually after some field measurement and software analysis. This is, however, time-consuming and unsuccessful many times.

With the uses of the artificial intelligence, telecommunication and power electronics equipments in the power system, it is becoming easier to automate the phase balancing problem. The automation implementation will be technically advantageous as well as economical for the utilities and the customers, in terms of the variable costs reduction and better service quality, respectively.

One particular case of distribution is in “town houses” or block of flats where a significant number of single-phase customers are connected to a distribution transformer. Due to the random nature of the consumption a big phase unbalance takes place; evenly phase connection of the loads in groups of three (see Fig.1) does not guarantees load balancing. Automatic balancing could be implemented taking as variables only the loads connected in the respective “distribution/connection box”.



Fig.1 Customers distribution box

The approach proposed here uses the neural network in comparison with the heuristic method which will be able to turn ON/OFF the different switches and keep the phases balanced. Each load will cater only one of the three phases following the constraint that for each load only one switch (to the phase) should be closed, while other two should remain

D. V. Nicolae is with the Department of Electrical Engineering, Thswane University of Technology, P.O.Box X680, Pretoria 0001, South Africa (e-mail danaurel@yebo.co.za).

M. W. Siti is with the Department of Electrical Engineering, University of Johannesburg, P.O.Box X680, Pretoria 0001, South Africa (e-mail willysiti@yahoo.com).

A.A. Jimoh is with the Department of Electrical Engineering, Thswane University of Technology, P.O.Box X680, Pretoria 0001, South Africa (e-mail Jimohaa@tut.ac.za).

open. For each loading condition, the neural network will be trained for the relevant minimum loss configuration. This can be applied to any small networks, such as groups of six up to fifteen houses as the unbalanced loads.

II. INTRODUCTION

A. Background and Basic Considerations

To balance the three phase currents in every segment and then depressing the neutral line current is a very difficult task for the distribution engineers considering the fact that they do not have control over their customers. Most of the time load balancing is done manually. Based on expert knowledge, this is usually done by changing the connection phases of a few critical distribution points to the specific primary feeder by measuring the three phase currents of the transformers. The balance of a feeder, in which the connection phases of some distribution systems are rearranged, might be improved but usually the change do not last for a long period of time. It is a matter of fact that the possibility of finding a good connection scheme to keep the phase to be balanced is almost impossible by using only the trial and error approach. Using this manual trial and error technique, interruption of the service continuity is unavoidable when changing the connection phases of distribution transformers to the feeder.

B. Representation of the Feeder

In South Africa, a distribution feeder is usually a three phases, four wire system. It can be radial or open loop structure. The size of the conductor for the entire line of the feeder is the same. However the number of phase conductors may be different in different sections for economic reasons. The example feeder shown in Fig. 2 has three phase four wires for the section between the main transformer and the different load points. To improve the system phase voltage and current unbalances, the connection between the specific feeder and the distribution transformers should be suitably arranged/rearranged using static switch with zero crossing action (Fig. 3). The benefits will be reduced loss and better performance of the network.

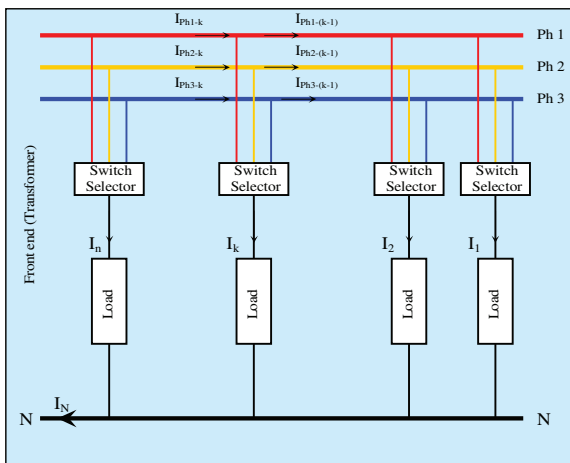

Fig. 2 Example of distribution feeder

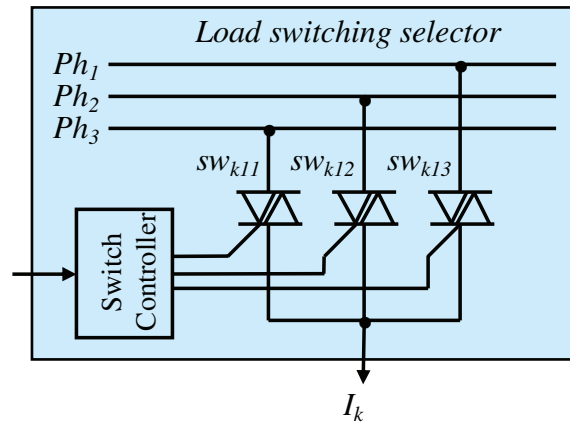

Fig. 3 Load switch selector

Fig. 4 shows the switching mechanism: at moment t_1 , the reconfiguration algorithm decides the load i_k should be changed from phase 1 to phase 3. The switch controller switches OFF the connection with phase 1 at zero crossing – moment t_2 and connects the load with the phase 3 at the next zero crossing – moment t_3 .

The switching from one phase to another will be seen as deep with the maximum duration of 17 msec; this very short deep does not affect any appliance in the house hold.

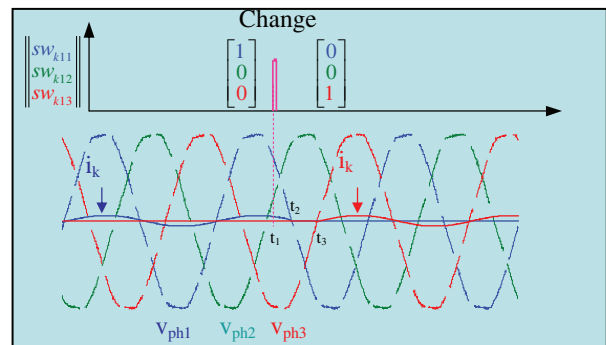

Fig. 4 Switching mechanism

III. PHASE BALANCING TECHNIQUES

In general, distribution loads show different characteristics according to their corresponding distribution lines and line sections. Therefore, load levels for each time period can be regarded as non-identical. In the case of a distribution system with some overloaded and some lightly loaded branches, there is the need to reconfigure the system such that loads are transferred from the heavily loaded to less loaded feeders. The maximum load current which the feeder conductor can take may be considered as the reference. Nevertheless, the transfer of load must be such that a certain predefined objective is satisfied. In this case, the objective is to ensure the network has minimum real power loss. Consequently, phase balancing may be redefined as the rearrangement of the network such as to minimize the total real power losses arising from line branches. Mathematically, the total power loss can be expressed as follows [7-9]:

$$P_{Loss} = \sum_{i=1}^n r_i \frac{P_i^2 + Q_i^2}{|V_i|^2} \quad (1)$$

where, r_i , P_i , Q_i , V_i are respectively the resistance, real power, reactive power and voltage of branch i , and n is the total number of branches in the system. The aim of this study is to minimize the power loss represented by (1) subject to the following constraints.

The voltage magnitude of each node of each branch V_j must lie within a permissible range. Here a branch can be a transformer, a line section or a tie line with a sectionalizing switch.

$$V_j^{\min} \leq |V_j| \leq V_j^{\max} \quad (2)$$

The relationship per phase between no-load voltage (V_{0j}), internal impedance (Z_j) and load current (I_j) is shown in (3), where V_j , I_j and Z_j are complex phasors and $j=1, 2, 3$.

$$V_j = V_{0j} - Z_j I_j \quad (3)$$

Given the above dependency between voltage and load current, this study will focus on the currents. Due to some practical considerations, there could be a constraint on the number of switch-ON & switch-OFF. For the distribution system as shown in Fig. 1, a network with 3 phases with a known structure, the problem consists of finding a condition of balancing. The mathematical model can be expressed as:

$$I_{ph1k} = \sum_{i=1}^3 sw_{ki1} I_{ki} + I_{ph1(k+1)} \quad (4)$$

$$I_{ph2k} = \sum_{i=1}^3 sw_{k2i} I_{ki} + I_{ph2(k+1)} \quad (5)$$

$$I_{ph3k} = \sum_{i=1}^3 sw_{k3i} I_{ki} + I_{ph3(k+1)} \quad (6)$$

where, I_{ph1k} , I_{ph2k} and I_{ph3k} represent the currents (phasors) per phase (1, 2 & 3) after the k point of connection; $sw_{k11} \dots sw_{k33}$ are different switches (the value of '1' means the switch is ON and '0' means it is OFF). I_{k1} , I_{k2} and I_{k3} represent different load currents (phasors) connected to the distribution system at point k of connections. The constrains of the switches involved in equations (4) to (6) can be written as:

$$\sum_{i=1}^3 sw_{ki1} - 1 = 0 \quad (7)$$

$$\sum_{i=1}^3 sw_{k2i} - 1 = 0 \quad (8)$$

$$\sum_{i=1}^3 sw_{k3i} - 1 = 0 \quad (9)$$

IV. NEURAL NETWORK METHOD

In the proposed strategy of this paper, the neural network must control the switch-closing sequence of each load for the optimal phase balance which will lead to the minimum power

loss. The inputs to the neural network are the unbalanced load currents fifteen in the current study) and the outputs are the switch closing sequences for each load.

The input layer of the network has N input neurons, N being the number of unbalanced load currents to be controlled. The following column vector has been assumed as the input:

$$C = [I_{L1} \dots \dots \dots I_{LN}]^T \quad (10)$$

The output of the network is in the range $\{1, 2, 3\}$ for each load, i.e. which switch (to the specific phase) should be ON for that specific load and moment in time.

A. Neural Network Structure

The radial basis network [3] has been used for this application. Experimentations with the back propagation and the radial basis network indicated faster training and better convergence for the last (radial basis network). Radial basis networks may require more neurons than the standard feed-forward back propagation networks, but often they can be designed in a fraction of the time needed to train the standard feed-forward networks. They work best when many training vectors are available [4]. Matlab[®] neural network toolbox [8] has been used for the implementation. As result of repeated simulations with different kinds of radial basis networks, the generalized regression neural network (GRNN) [8] produced the best result; a generalized regression neural network is often used for function approximation. It has a radial basis layer and a special linear layer.

B. Network Training

The neural network-based operation has been used for the test data in following structure: real and simulated data for fifteen loads.

The real data set consisted of unbalanced load data from a South African city. The test data set consist of average load current values per houses in a specific locality of the city for the different times of each day in a month, fifteen houses have been randomly selected as test data for each specific time, and the result had been tested for 500 data. Simulated data were generated using the computer following the real load data structure.

Firstly, the Matlab[®]-based fast heuristic method [8] has been used for balancing the unbalanced load data. Details of the algorithm can be referred to in [8], but herewith a brief explanation is presented:

Let's consider the loads to be equally distributed per phase, i.e., assume two loads to be connected per phase. So, the problem is to find the optimum three sets of two loads, with *minimum* differences among the individual sums of the three sets. To achieve this, the ideal phase balance current value I_{ideal} is firstly calculated, which is equal to the one-third of the sum of the all fifteen load currents I_L :

$$I_{ideal} = \frac{1}{3} \sum_{j=1}^{15} I_{L_j} \quad (11)$$

In the second step, we optimally select our 3 sets of currents for the three phase currents I_{ph} , each set comprising of two load currents $\{I_j, j=1,2\}$.

$$I_{Load} = \{I_{L_j}, j = 1, \dots, 15\} \quad (12)$$

$$I_{ph} = \{I_j, j = 1, 2\} \quad \text{where } I_j \in I_{Load} . \quad (13)$$

The difference between the individual sum of these sets and the I_{ideal} should be **minimum**, ideally 0 for the perfect phase balance. So, it is needed to find three sets of $\{I_j, j = 1, 2\}$, subject to the constraint:

$$\min \left| \sum_{j=1}^2 I_j - I_{ideal} \right|, \quad \text{where } I_j \in I_{Load} \quad (14)$$

Following this, the output switching sequences are obtained as the target data set for training the networks. The balanced phase currents I_{ph1} , I_{ph2} and I_{ph3} have been computed using the output switching sequences and the input load currents. For example, I_{ph1} is calculated by adding the two load currents corresponding to the output switching sequences marked "1". Then the differences between I_{ph1} , I_{ph2} and I_{ph3} have been computed, which ideally should be zero. The differences indicate the quality of the phase balance [1].

The above-mentioned neural network is then trained using the real and simulated unbalanced load as the input vector, and the output switching sequences as the target vector. Then, the network is tested with different unbalanced load data set. The output was the optimal switching sequences of $\{1, 2, 3\}$ for the three-phases as explained above. Using the similar procedure as explained above, the balanced phase currents have been computed and the differences between the phase currents and the results indicate the quality of the balance.

V. HEURISTIC METHOD

To perform the phase balancing a heuristic method is proposed in this paper on the sample distribution system shown in Fig. 2 which consists of 15 loads, each having three switches to the three phases in order to be connected to any of them. Following (7)-(9), the logic of load connection should be that: for each load, only one switch should be closed, other two should remain open, i.e., each load should cater only one of the three phases. The load currents are referred by the term 'load'. The following initial assumptions should be considered for the proposed method:

- i. The present algorithm should be applied to 15 loads only.
- ii. The loads should be considered equally distributed per phase, i.e. 5 loads to be connected per phase.

So, the problem is: to find the optimum three sets of five loads, with minimum differences among the individual sums of the three sets. To achieve this, first we calculate the ideal phase balance current value I_{ideal} , which is equal to the one-third of the sum of the all 15 load currents I_L .

$$I_{ideal} = \frac{1}{3} \sum_{j=1}^{15} I_{L_j} . \quad (15)$$

In the second step, optimally select 3 sets of currents for the three phase currents I_{ph} , each set comprising of 5 load currents $\{I_j, j = 1, \dots, 5\}$.

$$I_{Load} = \{I_{L_j}, j = 1, \dots, 15\} , \quad (16)$$

$$I_{ph} = \{I_j, j = 1, \dots, 5\} \quad \text{where } I_j \in I_{Load} . \quad (17)$$

The difference between the individual sum of these sets and the I_{ideal} should be **minimum**, ideally 0 for the perfect phase balance. So, three sets of $\{I_j, j = 1, \dots, 5\}$ have to be found, subject to the constraint:

$$\min \left| \sum_{j=1}^5 I_j - I_{ideal} \right|, \quad \text{where } I_j \in I_{Load} . \quad (18)$$

VI. HEURISTIC METHOD - IMPLEMENTATION

The proposed heuristic method has been implemented using MATLAB® [11]. The implementation takes as input the sequence of 15 load currents. It returns as output the sequence of the switch closing for each load, i.e., integer 1,2 or 3 for each load, where 1,2,3 represents the switches for the respective phases as shown in Fig. 1&2. Using the output switch closing sequence and the load currents, we can calculate the three balanced phase currents and the differences between them, which indicate the quality of the phase balance. The implementation steps are depicted in the flowchart shown in Fig. 4.

In Fig. 4, the left chart shows the main algorithm, and right chart shows a subroutine which is explained gradually below.

A. Main Algorithm

The main algorithm for the implementation of the heuristic method is shown in the left flowchart in Fig. 5. The sequential steps are as follows:

- The 15 load currents are considered as vector.
- The output vector of the switching sequences is initialized for each load, which is also a vector of 15 elements.
- Then the I_{ideal} is computed using (10).
- Check all the 15 loads to find the *first* set of 5 load currents, i.e., for I_{ph1} optimally ON to I_{ideal} . This is done by the subroutine 'Calculate set of 5', shown in the right chart in Fig. 4, and explained later.
- The output switching sequence for I_{ph1} is updated by marking it "1".
- Then remaining 10 loads are checked to find the second set of 5 load currents, i.e.: for I_{ph2} optimally ON to I_{ideal} . This is also done by the subroutine: 'Calculate set of 5'.
- The output switching sequences for I_{ph2} is updated by marking those 2.

- After finding the sequences for I_{ph1} and I_{ph2} the rest 5 load currents will be allocated to I_{ph3} .
- The output switching sequences for I_{ph3} will be updated by marking those 3.
- The output switching sequences for I_{ph3} will be updated by marking those 3.
- Using the output switching sequences of 1, 2, 3 for I_{ph1} , I_{ph2} and I_{ph3} and the input load currents, the balancing between phase currents I_{ph1} , I_{ph2} , and I_{ph3} is computed. For example: I_{ph1} is calculated by adding all the 5 load currents corresponding to the output switching sequences marked 1.
- Then the differences between I_{ph1} , I_{ph2} and I_{ph3} is calculated which ideally should be zero. It indicates the quality of the phase balance.
- The program returns:
 - The output switching sequence;
 - The phase currents I_{ph1} , I_{ph2} and I_{ph3} ;
 - The differences between the phase currents.

B. Subroutine: “Calculate set of 5”

The subroutine ‘Calculate set of 5’ used to choose the output sequences for I_{ph1} and I_{ph2} is presented; the sequential steps are:

- For I_{ph1} , we start with the 15 load currents.
- Mark the first element as 1.
- Iterate over 14 load currents for every possible combinations of the set of 4 load currents. The elements in the sets are placed position independently, i.e. {1, 2, 3, 4} is same as {2, 1, 4, 3}.
- For each possible set, the difference parameter (ϵ) is calculated:

$$\epsilon = I_{ideal} - \sum \text{set of 4 currents} - \text{first current}$$
- Choose the set with the **minimum** value of ϵ as the optimum balance set.
- We return the set for the I_{ph1} .
- For I_{ph2} , start with the 10 load currents.
- We mark the first element as 2.
- Iterate over 9 load currents for every possible combinations of the set of 4 load currents. The elements in the sets are independently placed positions, i.e. {1, 2, 3, 4} is same as {2, 1, 4, 3}.
- For each possible set, the difference parameter (ϵ) is calculated:

$$\epsilon = I_{ideal} - \sum \text{set of 4 currents} - \text{first current}$$
- Choose the set with the **minimum** value of ϵ as the optimum balance set.
- Return the set for the I_{ph2} .

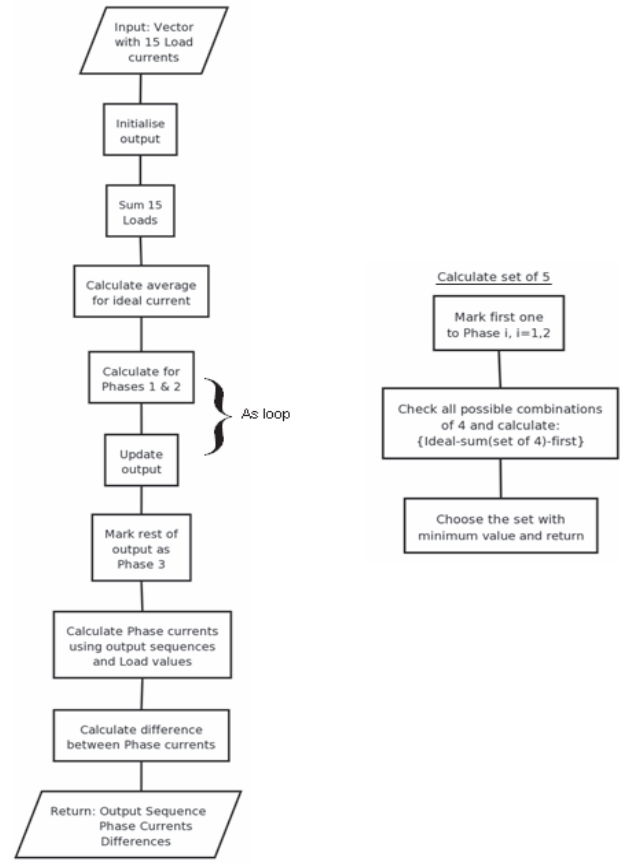

Fig 5: Flowchart of the implementation of the heuristic method for load balancing

VII. SIMULATION RESULTS

A. Real Data

Firstly, the algorithm was tested on real data received from local electricity supply. The test data set had average load current values per houses in a specific locality of the city for different times of each day in a month. Randomly 15 houses have been selected as test data for each specific time, and tested result on 500 data base randomly has been created for the trial of this two algorithms, three set of currents each have been randomly chosen.

An Intel® Celeron® 1.9 GHz, 256 MB RAM computer was used for the test. Test results of the neural network-based approach for the simulated fifteen load data format are shown in Table I to III, for three different sample data. Table I shows the unbalanced load (current) data, Table II the output switching sequences, and Table III the balance phase currents. In Table II to III, ‘NN’ is the abbreviation for the Neural Network - based approach, ‘HE’ is the abbreviation for the Heuristic Method based approach and ΔI is the phase difference.

TABLE I
UNBALANCE LOAD CURRENTS (DATA)

Sets of Data Loads	Data		
	1	2	3
1	94.06	40.16	1.51
2	22.88	92.61	73.93
3	60.07	90.77	44.06
4	48.11	40.61	92.24
5	88.23	88.47	46.13
6	75.44	5.73	41.44
7	45.19	34.93	83.77
8	1.83	80.50	51.99
9	81.31	0.97	20.06
10	60.92	13.75	66.54
11	78.40	20.07	82.97
12	91.25	19.67	1.94
13	73.08	59.77	67.44
14	17.45	26.94	37.56
15	44.02	19.68	82.34

TABLE II
OUTPUT SWITCHING SEQUENCES

Loads	Switching matrix for the first set of data		Switching matrix for the second set of data		Switching matrix for the third set of data	
	NN	HE	NN	HE	NN	HE
1	1	1	1	1	1	1
2	2	2	2	1	2	2
3	1	1	3	2	3	3
4	3	3	1	3	1	2
5	1	3	3	3	1	1
6	1	3	1	1	2	2
7	2	2	3	3	3	3
8	3	3	1	2	1	1
9	2	3	2	2	3	2
10	1	1	1	1	2	3
11	3	2	3	2	2	1
12	2	1	2	2	3	3
13	2	2	3	1	1	3
14	2	2	2	3	1	2
15	1	1	2	3	1	1

TABLE III
BALANCE PHASE CURRENTS

	Data Set 1		Data Set 2		Data Set 3	
	NN	HE	NN	HE	NN	HE
I_{ph1} (A)	189.8	294.1	200.7	293.3	256.2	294.9
I_{ph2} (A)	213.8	212.1	187.6	212.0	207.6	263.7
I_{ph3} (A)	154.9	265	123.7	265.3	123.6	263.8
ΔI_{ph-max} (A)	24	2	77	28	133	31
T_c (sec)	0.14	0.14	0.17	0.14	0.14	0.14

B. Comments on Application Results

- Summary of the neural network-based approach in comparison with the heuristic method, the result shown in table 3, proves that the heuristic method have a better phase balancing compare to the neural network based approach.
- Average computation time (T_c) 0.14 seconds is similar with the heuristic method, once the network is trained. For this reason, once the network is suitably trained, we save and use it as a neural network object.
- This approach can be extended to any number of unbalanced load data. The immediate effect will be the increase of the computing time; for radial feeder of up to one hundred households, the computing time could be in the range of few seconds. Also the dynamic of the loads is random the rate of change is slow which makes insignificant an unbalance of few seconds duration.

VIII. CONCLUSION

Phase balancing is a very important operation to reduce distribution feeder losses and improve system security. The determination of an optimal phase balancing is, in general, a combinatorial optimization problem.

This paper projects a MATLAB based fast heuristic and the neural network method for load balancing. The methods were successfully tested and validated using data collected from suburb of Garankuwa. From practical point of view this method can be very effective as several model-based approaches usually take very long running time [10-11].

The simulation results of these two methods can be seen as validation of the proposed automation algorithm.

IX. REFERENCES

- [1] S.Civanlar and J.J. Grainger. Distribution feeder reconfiguration for loss reduction,"IEEE Trans. PWRD-3,pp.127-1223,1998
- [2] T.H. Chen and J.T. Cherg, "Optimal Phase Arrangement of Distribution Transformers Connected to a Primary Feeder for System Unbalance Improvement and Loss Reduction Using Generic Algorithm," *IEEE Trans. Power Systems*, vol. 15, no. 3, Aug 2000.
- [3] C.C Liu, S. J. Lee, and K. Vu, "Loss Minimization of Distribution Feeders: Optimality and Algorithms," *IEEE Trans. Power Delivery*, vol. 4, no. 2, Apr 1989.
- [4] C.B. Alexandre, A. Carlos and Newton, "Main Chain Representation for Evolutionary Algorithms Applied to Distribution System Reconfiguration," *IEEE Trans. Power Systems*, vol. 20, no. 1, Feb 2005.
- [5] M.E Baran and F.F Wu, "Network Reconfiguration in distribution Systems for Loss Reduction and Load balancing," *IEEE Trans. Power Delivery*, vol. 7, no. 2, Apr 1989.
- [6] M. Siti, A.A Jimoh and D. Nicolae " Load Balancing in distribution feeder Through Reconfiguration" IECON05, Raleigh, North Caroline, 6-12 Nov. 2005
- [7] M. Siti, and A.A Jimoh, "Reconfiguration circuit loss minimization through feeder reconfiguration," in *Proc. SAUPEC Conf.*, Stellenbosch, South Africa, 2004.
- [8] Matlab documentation – Neural Network toolbox, Version 6.5 0.180913a Release 13, Math works Inc., Natick, MA(2002)
- [9] C.S Chen and M.Y. Cho, "Energy Loss Reduction by Critical Switches, of Distribution feeders for Loss minimization," *IEEE Trans. Power Delivery*, vol.4, no.2, Jul 1992.
- [10] X. Yang, S.P. Carull and K. Miu, "Reconfiguration Distribution Automation and Control Laboratory: Multiphase Radial Power Flow Experiment," *IEEE Trans. on Power Systems*, vol. 20, no. 3, Aug 2005.
- [11] A. Auguglio, L. Dusonchet and M. Giuseppe, "Minimum Losses Reconfiguration of MV distribution Networks through Local Control of Tie-switches," *IEEE Trans. on Power Delivery*, vol.18, no. 3, Jul 2003.