

Distribution Feeder Phase Balancing using Newton-Raphson Algorithm-based Controlled Active Filter

M.W. Siti, D.V. Nicolae, J.A. Jordaan and A.A. Jimoh

Graduate School of Electrical and Electronic Engineers, Tshwane University of Technology
Private Bag X07, 0116, Pretoria North, South Africa

E-Mail: willysiti@yahoo.com, danaurel@yebo.co.za, jordaan.jaco@gmail.com, jimohaa@tut.ac.za

Abstract. The distribution system problems, such as planning, loss minimization, and energy restoration, usually involve the phase balancing or network reconfiguration procedures. The determination of an optimal phase balance is, in general, a combinatorial optimization problem. This paper proposes a novel reconfiguration of the phase balancing using the active power filter control and the combinatorial optimization-based Newton-Raphson algorithm to solve the unbalance problem. By utilizing the load switches as state variable, a constant Jacobian matrix can be obtained. The model developed in this paper uses combinatorial optimization techniques to translate the change values (kVA) into a number of load points and then selects the specific load points. It also performs the inter-changing of the load points between the releasing and the receiving phases in an optimal fashion. Application results balancing a distribution feeder network in South Africa for domestic loads are presented in this paper.

1. Introduction

The distribution system will typically have a great deal of single-phase loads connected to them. Therefore distribution systems are inherently unbalanced. The load is also very dynamic and varies with time; these factors contribute to increase difficulties in controlling the distribution voltage within certain limits. In addition to this most of the time the phases are unequally loaded and they produce undesired negative and zero sequence currents. The negative sequence will cause excessive heating in machines, saturation of the transformers and ripple in rectifiers [1, 2], Phase balancing is very important and usable operation to reduce distribution feeder losses and improve system security.

In South Africa, to reduce the unbalance current in a feeder the connection phases of some feeders are changed manually after some field measurement and software analysis. Although in some cases this process can improve the phase current unbalance, this strategy is more time-consuming and erroneous, but it is important to balance the three phase voltages. The conventional solution using a passive compensator has been used as a solution to solve voltage unbalance [1], but this presents several disadvantages namely

resonance can occur because of the interaction between the compensator and the load, with unpredictable results. To cope with these disadvantages, recent efforts have been concentrated in the development of active filters [2, 3]. Using three-legged power converters to deal with the unbalanced load and source has been addressed in [3]. By engaging a feed forward control, the negative-sequence component caused by an unbalanced source/load can be cancelled out so that the input power becomes constant and the DC link voltage is free of low frequencies, even harmonic ripples. However, a three-legged power converter is incapable of dealing with zero sequence unbalance. To solve the problem, normally split DC link capacitors are used. The zero-sequence current path is provided by connecting the neutral point to the middle point of the two DC link capacitors [3]. The drawback of this model is that excessively large DC link capacitors are needed; therefore the cost is high for high voltage applications. In [2] they propose the four-legged inverter. In a three-phase wire system there is always difficulties to reduce the zero sequence current. In this paper, the active filter combined with the Newtown-Raphson method (NR) will be applied to achieve the balance.

In section 2, 3 and 4 the proposed model and Newton-Raphson based controller is introduced. Section 5 shows some results and the paper ends with conclusions.

2. Proposed model

In general, distribution loads show different characteristics according to their corresponding distribution lines and line sections. Therefore, load levels for each time period can be regarded as non-identical. In the case of a distribution system with some overloaded and some lightly loaded branches, there is the need to balance the system such that the loads are rearranged. The maximum load current, which the feeder conductor can take, may be considered as the reference. Nevertheless, the rearranging of loads must be such that a certain predefined objective is satisfied. In this case, the objective is to ensure the network has minimum real power loss.

In [4] is presented an artificial neural network algorithm (ANN) applied for a small distribution feeder with six loads. Some results of ANN load balancing for 15 consumers are presented in Table 1. The table shows the current after load balancing in each of the three phases (for three different test cases), as well as the largest difference between the three phase currents. As can be seen from Table 1, after applying ANN there still is an unbalance. In this paper, which is a continuation of [4], a further effort is proposed to optimally balance the feeder by means of an active power filter (APF) working in an unbalanced system.

TABLE I
BALANCED PHASE CURRENTS OF THE ANN

	1 ST Data Set	2 ND Data Set	3 RD Data Set
I_{ph1} (A)	270.9	175.5	299.6
I_{ph2} (A)	304.1	245.2	227.4
I_{ph3} (A)	307.3	213.9	266.9
ΔI_{ph-max} (A)	36.4	69.7	72.2

In general, an active power filter is a device that cancels harmonic current from the non-linear loads and compensates reactive power. In the configuration shown in Fig. 1, The APF is connected in parallel to the load in order to compensate the remaining unbalance after applying the neural network algorithm. The control of this APF is based on the Newton-Raphson method. Thus, after the minimization of the unbalance, the efficiency of the distribution transformer will be improved.

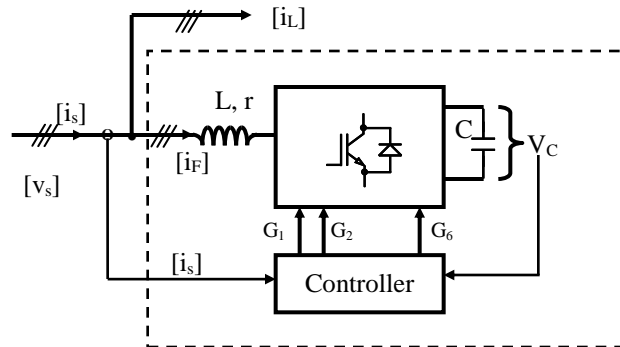

Fig. 1: Active power filter in parallel with a partially balanced feeder

3. Power balance principle

This analysis is intended to clarify the power exchange between the supply, non-linear load (which could be in the form of reactive power, harmonics or unbalance) and the converter while it performs simultaneous functions of unity power factor rectification – as the main function, reactive power compensation, harmonic compensation (active power filter) and unbalancing correction. Throughout the analysis the AC bus will be considered

to be infinite and no voltage distortion is taking place. Neglecting the losses of the bridge converter (**H** topology), the relation between the instantaneous powers delivered by the supply (p_s), the instantaneous power drawn by the non-linear load (p_L) and the switching-mode converter (p_c) can be written as:

$$P_s = P_L + P_c \quad (1)$$

The parameters of the supply are:

$$[v_s]^T = \sqrt{2} \times V_s \sin \left[\omega t - \frac{2\pi}{3}(i-1) \right] \quad (2)$$

with $i = 1,2,3$ and t meaning vector transpose,

$$[i_s]^T = \sqrt{2} \times I_s \sin \left[\omega t - \frac{2\pi}{3}(i-1) \right] \quad (3)$$

with $i = 1,2,3$ and where V_s and I_s are the rms value of the supply voltage and current respectively.

$$[i_L]^T = \sum_{h=1}^{\infty} \sqrt{2} \times I_L \sin \left[h \times \left(\omega t - \frac{2\pi}{3}(i-1) \right) - \varphi_h \right] \quad (4)$$

$$P_L = [v_s]^T \cdot [i_L] = 3 \cdot V_s \cdot I_{L1} \cdot \cos \varphi_1 + \sum_{h=2}^{\infty} P_{3h} \cdot \cos(3h\omega t - \varphi_{3h}) \quad (5)$$

where:

$$P_{3h} = 3V_s \sqrt{I_{L(3h-1)}^2 + I_{L(3h+1)}^2 + 2I_{L(3h-1)}I_{L(3h+1)} \cos(\varphi_{3h+1} - \varphi_{3h-1})} \quad (6)$$

and

$$\tan \varphi_{3h} = \left(I_{L(3h+1)} \sin \varphi_{3h+1} + I_{L(3h-1)} \sin \varphi_{3h-1} \right) / \left(I_{L(3h+1)} \cos \varphi_{3h+1} + I_{L(3h-1)} \cos \varphi_{3h-1} \right) \quad (7)$$

The instantaneous power drawn by the non-linear load is:

$$p_L(t) = P_L + \tilde{p}_L(t) \quad (8)$$

where P_L is the active power used by the non-linear load and $\tilde{p}_L(t)$ is the instantaneous fluctuant/distortion power due to the same non-linear load.

$$P_L = 3 \cdot V_s \cdot I_{L1} \cdot \cos \varphi_1 \quad (9)$$

After compensation the instantaneous power delivered by the supply is:

$$p_s = [v_s]^T \cdot [i_s] = P_s = 3 \times V_s \times I_s \quad (10)$$

where P_s is the dc component of $p_s(t)$ and represents the active power delivered by the supply.

The instantaneous power transferred through the active converter is:

$$p_c(t) = p_L(t) - P_s + P_o = P_L - P_s + \tilde{p}_L(t) = P_c + \tilde{p}_c(t) \quad (11)$$

where P_o is the active power delivered to dc bus.

$$\text{But: } P_c = P_L - P_s + P_o \quad (12)$$

$$\text{Therefore: } \tilde{p}_c(t) = \tilde{p}_L(t) \quad (13)$$

In steady state, the fluctuating power $\tilde{p}_c(t)$ at the output of the active converter compensates the fluctuating power of the non-linear load which could be in the form of reactive power, harmonics or unbalance. Equation (12) expresses the active power exchange between the supply, non-linear load and active converter. If the losses in the **H** converter are neglected, then the fluctuating power $\tilde{p}_c(t)$ is converted into the ripple voltage $\tilde{v}_o(t)$ across the condenser. When a transient change in the active power demanded by the load occurs, the storage element (C) should be capable of compensating this unbalance. This results in a variation of the dc bus voltage. If the active power delivered by the source was inferior to the load demand ($P_c > 0$), then the average (V_o) voltage across the capacitor decreases. If the load demands less active power ($P_s < 0$), then V_o increases. The variation of the dc bus is compensated for by the voltage regulator.

4. Control System

For this application of the APF, the control system is shown in Fig. 2. The switching matrix, which is used in the control system, is computed using the Newton-Raphson algorithm, which is presented next. For the mentioned system, we propose, in this paper, an active power filter balancing technique along with a combinatorial optimization oriented Newton system for implementing the load change decision.

With reference to Fig. 2, I_{si} represents the source current that should be minimized

$$I_{si} = I_{Fi} + \frac{V_{Li} - V_{ref}}{Z_{Li}} \quad (14)$$

with $i = 1, 2, 3$.

Where I_{Fi} is the active power filter current, V_{Li} represents the voltage across each load and Z_{Li} is the impedance of each load.

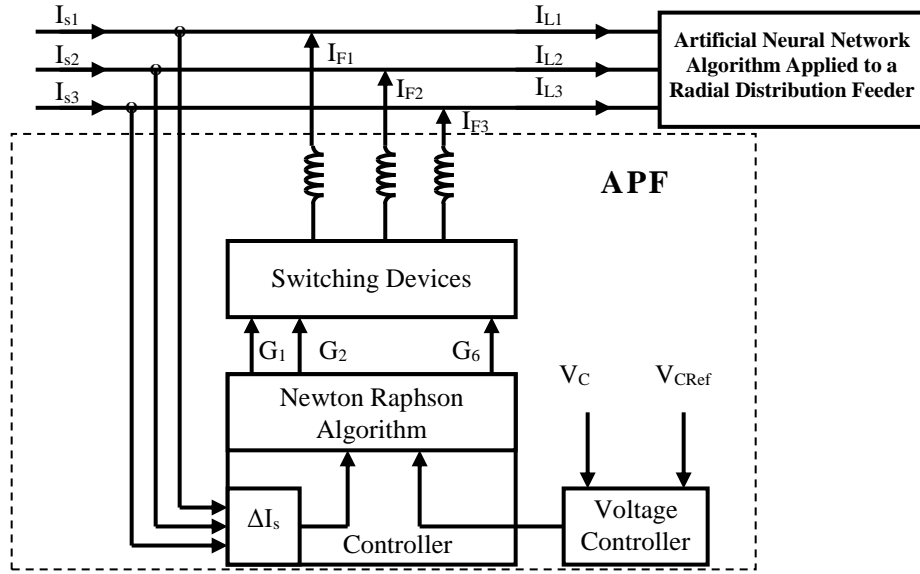

Fig.2 Control system

Therefore, the objective of this new algorithm is to minimize the difference of the amplitude of the phase currents I_{S_i} .

$$\text{Minimize } \begin{vmatrix} I_{s1} - I_{s2} \\ I_{s2} - I_{s3} \\ I_{s1} - I_{s3} \end{vmatrix} \quad (15)$$

The Least Squares objective function proposed for this study is:

$$J = (I_{s1} - I_{s2})^2 + (I_{s1} - I_{s2})^2 + (I_{s1} - I_{s2})^2 \quad (16)$$

When the objective function (16) is minimized, the power losses in the system will also be reduced. This procedure results in a non-linear system of equations that will be solved using Newton-Raphson. To solve the minimization problem, the gradient of the least square objective function J as defined in (16), can be expressed in terms of x , where

$x = [sw_1, sw_2, \dots, sw_6]$ is the vector of the APF switches. Then the gradient J_x should be equal to zero.

$$J_x = \left[\frac{\partial J}{\partial sw_1}, \frac{\partial J}{\partial sw_2}, \dots, \frac{\partial J}{\partial sw_6} \right] = 0 \quad (17)$$

Equation (17) is a system of non linear equations. To solve the system of non linear equations, the system should be linearized around some working points x_k by using a truncated Taylor series expansion:

$$J_{xx}(x_k)\Delta_{xk} + J_x(x_k) = \mathbf{0}, \quad (18)$$

where $J_{xx}(x_k)$ is the 6×6 Hessian matrix, containing the second order derivatives of the objective function J evaluated at point x_k , and $J_x(x_k)$ is the gradient of J evaluated at point x_k . The correction vector Δ_{xk} can then be calculated by solving the following system of linear equations:

$$J_{xx}(x_k)\Delta_{xk} = -J_x(x_k) \quad (19)$$

The initial value for the parameter vector x_k is arbitrary chosen and then an iterative procedure is used to obtain a better value of the parameter vector.

$$x_{k+1} = x_k + \Delta_{xk} \quad (22)$$

Fig. 3 shows the flow chart of the control process.

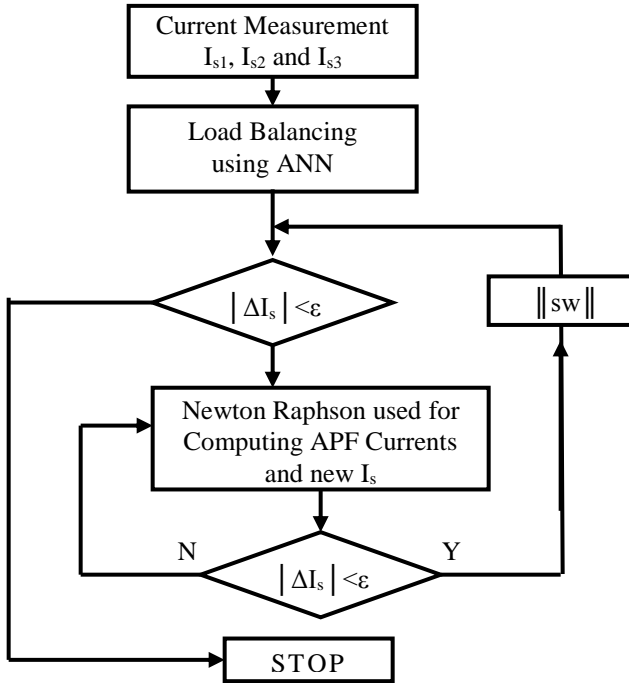

Fig. 3 Flow chart

5. Test Results

In order to illustrate the proposed balancing method, the group currents “data1” from Table 1 has been chosen. Fig. 4 shows the currents (I_{s1}, I_{s2}, I_{s3} in Fig. 2) after applying the artificial neural network algorithm.

Fig. 5 shows the filter currents (I_{F1}, I_{F2}, I_{F3} in Fig. 2) produced by the active power filter using the Newton-Raphson method to control the switching devices. Fig. 6 shows the result of active power filter distribution feeder balancing (phase currents I_{L1}, I_{L2}, I_{L3} in Fig. 2).

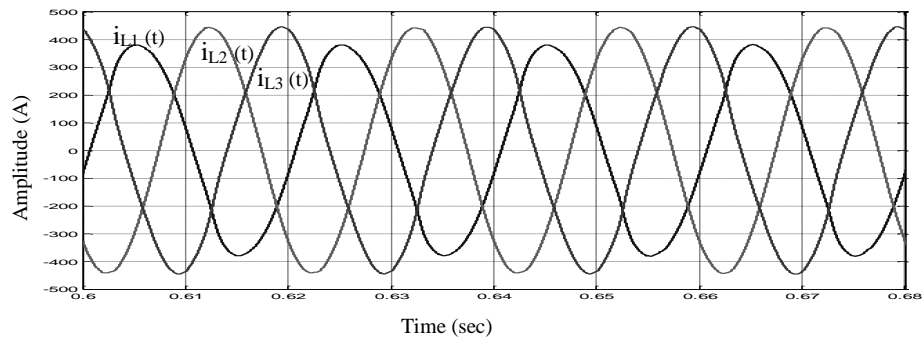

Fig. 4 Feeder currents partially balanced by ANN

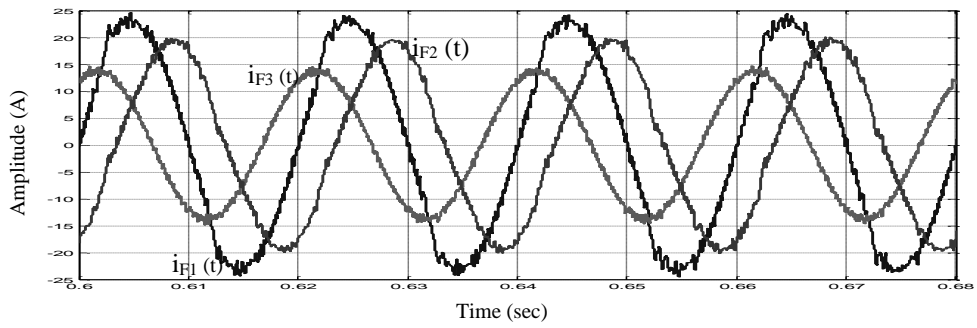

Fig. 5 Active power filter currents

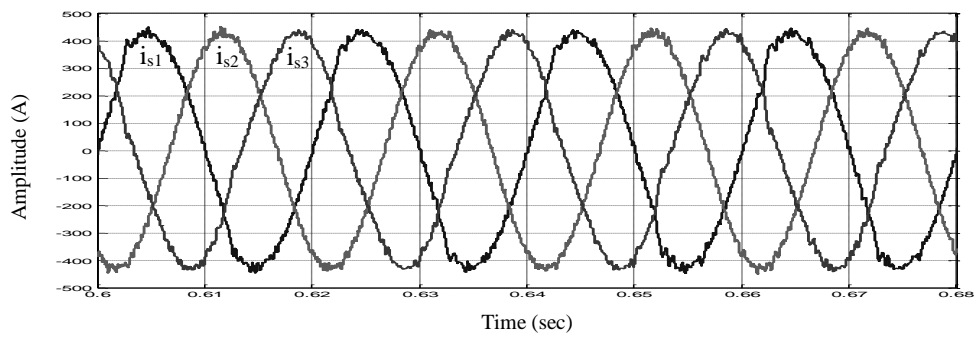

Fig. 6 Balanced feeder currents

From Fig. 4 – Fig. 6 it can be seen how the APF is injecting current from the partially ANN balanced system to correct any small scale unbalances that may still be in the system.

6. Conclusions

The use of a power electronic active power filter in conjunction with an artificial neural network for optimally mitigating unbalance in a distribution network feeder has been proposed and demonstrated. An analysis intended to clarify the power exchange between the supply, non-linear load and the converter while it performs simultaneous functions of unity power factor rectification – as the main function reactive power compensation, harmonic compensation (active power filter) and unbalancing correction has been presented. The switches of the APF are controlled for optimal phase unbalancing mitigation by using a Newton-Raphson algorithm to iteratively solve an optimization problem, which results are then used to control the voltage and current controller of the converter. The proposed method was implemented for a practical case with a satisfactory result.

References

- [1] Mark McGranaghan “Active Filter Design and Specification for control of Harmonics in Industrial and Commercial Facilities”, Electrotek Concepts, Inc.
- [2] Abdelaziz Chaghi, Amor Guettafi, Azzedine Benoidjit” Four Legged Active Power filter Compensation For a Utility Distribution System” Journal of Electrical Engineering, Vol. 55 No. 1-2 2004.
- [3] Juan W. Dixon, Gustavo Venegas and Luis A. Moran” A series Active Power filter Based on a sinusoidal Current- Controlled Voltage – Source Inverter” IEEE Transaction on Industrial Electronic Vol. 44 No. 5 October 1997
- [4] Ukil, M. Siti and J. Jordaan “Feeder Load Balancing Using Neural Network”, International Symposium on Neural Networks (ISNN 2006) held in Chengdu, China during May 28-31, 2006