

A Statistical Analysis of Metal Oxide Varistor Current under Distorted Supply Voltage Conditions

Pitshou Bokoro
School of Electrical and Information Engineering
University of the Witwatersrand, Johannesburg
South Africa
Email: 688331@students.wits.ac.za

Miidzo Hove
Electrical and Electronic Engineering Science
University of Johannesburg, South Africa
Email: mhove@uj.ac.za

Ian Jandrell
University of the Witwatersrand, Johannesburg
South Africa
Telephone: (011) 717-7204
Email: ian.jandrell@wits.ac.za

Abstract—Leakage current monitoring is still relied upon when on-site condition assessment or stability analysis of metal oxide varistors is to be conducted. The non-availability of adequate testing equipment, capable of directly measuring resistive component of varistor current, has paved the way to indirect diagnostic techniques which makes use of third harmonic component of varistor-arrester leakage current. The major shortcoming related to this method consists of high probability of measurement errors and subsequent misinterpretation of actual condition of varistor units should third harmonic-frequencies not be compensated in the supply voltage, prior to measurement. In this study, 90 identical low voltage varistor samples acquired from three leading manufacturers are subjected to distorted and non-distorted ac supply voltage. The magnitude of third harmonic currents observed in both measurement conditions, is deduced from the decomposition of time-domain leakage current waveforms into the frequency-domain using the flattop window algorithm of the Fast Fourier Transform. The large-sample statistical test of Hypothesis methodology is invoked to analyse the difference between the mean third harmonic currents of the varistor samples before and after harmonic injection in the supply. The average percentage of third harmonic injected in the supply voltage is 5%. However, the results obtained suggest over 95 % confidence that the measurement deviation in the third harmonic current-based assessment of varistor-arresters upon 5% third harmonic distortion in the supply voltage lies between 32% and 67%.

keywords: Metal Oxide Varistor; Third harmonic current; Large-sample statistical test of hypothesis.

I. INTRODUCTION

The stability of varistor arresters is quite essential to the achievement of effective and reliable surge protection in electrical circuits. Therefore, continuous monitoring of electrical and thermal properties of metal oxide varistors (MOV) is crucial means of an attempt to measure eventual deviations to standard operating characteristics of varistor arrester devices. Electrical condition of operating varistors could be revealed from the resistive component of the leakage current[1]. This ultimately implies complete removal of dominantly capacitive component of the varistor leakage

current, which appears to be practically challenging [2]. The proven proportionality between the supply voltage and third harmonic current (THC) component of the leakage current has provided quite a valid alternative technique to assess the condition of MOVs, namely: the THC-based assessment technique[3]. However, observations of THC components in non-compensated distorted ac circuits commonly lead to misinterpretation of varistor condition[4-5].

Digital signal processing (DSP) techniques incorporated in modern instrumentation and measurement enable the decomposition of time-domain waveforms into frequency-domain. This comes as great support to indirect estimation of MOV condition as demonstrated in [6]. The usual predicament in the THC-based assessment consists of the non-provision of rated value or normal range of THC by varistor manufacturers as well as the prevalence of harmonics in modern electrical circuits.

In this work, the large-sample statistical test of hypothesis is applied to evaluate the difference between the mean of the THC components, observed before and after 5% distortion of the supply voltage on 90 low voltage varistors. The results obtained prove that for third harmonic content of 5% in the supply voltage, the THC measurement deviation is estimated to lie between 32% and 67%.

II. METHODOLOGY

A. Varistor Sampling Technique

90 low voltage varistor samples, obtained from three leading manufacturers, are subjected to distorted and non-distorted supply voltage. The samples used represent reasonable estimates of varistor populations under each of the two experimental conditions. The deviation between the mean of the population and the observed samples or the percentage margin of error (ME) is estimated to be $\pm 0.14\%$. The test regime consisted of a 0-250 V, 50 Hz ac voltage

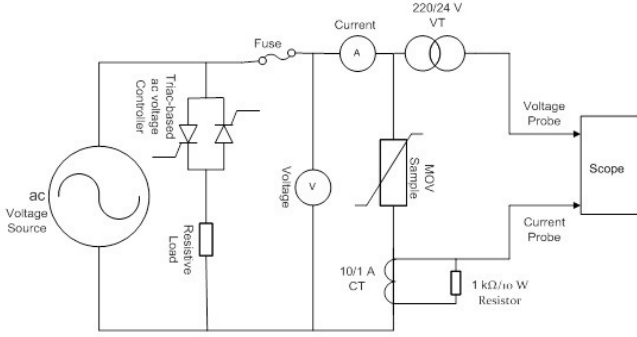

Fig. 1. Test Regime.

source connected across a low voltage (LV) varistor unit. To distort the clean waveform obtained from the voltage source, a triac-based ac voltage controller is connected across the varistor sample. The details of the test methodology leading to THC measurement under both conditions are discussed at great length in [6]. Figure 1 shows the test set-up.

The THC obtained from both experimental conditions are described in terms of the following statistical parameters: the mean value, the sample variance as well as the standard deviation. The third harmonic voltage component measured in the supply system for each varistor sample involved is averaged at 5%. The mean THC, the sample variances as well as the standard deviations, which apply to both conditions of the THC measurement, could be obtained using equations (1), (2) and (4), respectively.

$$\bar{i} = \frac{\sum i_i}{n} \quad (1)$$

Where: \bar{i} is the mean THC; i_i is the successive measurement points of the THC amplitudes from sample 1 to 90, and n is the number of samples involved or the sample size.

For $n \geq 30$, the sample variance is taken to be equal to that of the population [7]. It is therefore calculated using the following relationship:

$$s^2 = \frac{\sum (i_i - \bar{i})^2}{n - 1} \quad (2)$$

The standard deviation will therefore be:

$$s = \sqrt{s^2} \quad (3)$$

The ME obtained at 95% confidence is expressed as follows:

$$ME = \pm 1.96 \cdot \frac{s}{\sqrt{n}} \quad (4)$$

B. The Statistical Test of Hypothesis

Since the THC measurement deviation implies a comparison between the mean THC of two varistor populations represented in this study, the statistical test of hypothesis technique could

be applied in order to quantify the confidence interval in which the true value of the difference between the population means will lie. The following hypotheses are therefore formulated:

1. The Null hypothesis (H_0): To quantify the difference in the population means consists of disproving that the difference in the population means is equal to zero. This could be expressed as follows:

$$H_0 : \bar{\mu}_1 - \bar{\mu}_2 = 0 \quad (5)$$

Where: $\bar{\mu}_1$ is the mean THC of the varistor population subjected to voltage distortion and $\bar{\mu}_2$ is the mean THC of the varistor population under non-distorted voltage.

2. The Alternative hypothesis (H_1): This is the contradiction to the null hypothesis. The difference in the population mean THC is different to zero. This basically suggests that such a difference could either be higher or lower than zero. The mathematical expression of the alternative hypothesis is denoted as follows:

$$H_1 : \bar{\mu}_1 - \bar{\mu}_2 \neq 0 \quad (6)$$

3. The Test statistic (z): This is a measurement of the deviations if any, between the difference in the population means of the hypothesised value, which in this case is equal to zero. For $n \geq 30$, the z value is obtained from the sample data applying the following equation:

$$z = \frac{\bar{i}_1 - \bar{i}_2}{\sqrt{\frac{s_1^2}{n_1} + \frac{s_2^2}{n_2}}} \quad (7)$$

Where z is the test statistic, \bar{i}_1 and \bar{i}_2 are estimate mean THC of the varistor population under distortion and non-distortion, respectively. s_1^2 and s_2^2 are sample variances, and n_1 and n_2 are the sample sizes under respective observation conditions.

4. The rejection region: The rejection of the null hypothesis amounts to the validation of the alternative hypothesis. The rejection criteria is based on the critical value approach, using a two-tailed test at 0.95 or 95 % confidence level. Based on the critical values ($z_{\alpha/2}$) as well as the significance levels (α) provided on Table I, the null hypothesis will be rejected on the basis of the following condition:

$$z > 1.96 \text{ or } z < -1.96.$$

TABLE I
CRITICAL VALUES AND SIGNIFICANCE LEVELS

$(1 - \alpha)$	α	$z_{\alpha/2}$
0.90	0.10	1.645
0.95	0.05	1.96
0.98	0.02	2.33
0.99	0.01	2.58

The limits of the confidence interval in which the difference of the mean THC of the varistor population will lie are determined using the equation below:

$$(\bar{i}_1 - \bar{i}_2) \pm 1.96 \sqrt{\frac{s_1^2}{n_1} + \frac{s_2^2}{n_2}} \quad (8)$$

Equation 8 could further be rewritten as follows:

$$LCL \leq \bar{i}_1 - \bar{i}_2 \leq UCL \quad (9)$$

Where: LCL is the lower confidence limit and is expressed as follows:

$$LCL = (\bar{i}_1 - \bar{i}_2) - 1.96 \sqrt{\frac{s_1^2}{n_1} + \frac{s_2^2}{n_2}} \quad (10)$$

And UCL is the upper confidence limit which is in turn expressed as:

$$UCL = (\bar{i}_1 - \bar{i}_2) + 1.96 \sqrt{\frac{s_1^2}{n_1} + \frac{s_2^2}{n_2}} \quad (11)$$

Multiplying further all sides of equation (9) by the factor $(100/\bar{i}_2)$, will subsequently produce the interval in which the percentage deviation between the varistor population means will be located. This is given as:

$$\beta_1 \leq \frac{\bar{i}_1 - \bar{i}_2}{\bar{i}_2} \times 100 \leq \beta_2 \quad (12)$$

Where: β_1 and β_2 are the lower and upper limits of the percentage deviation between the mean THC of the varistor populations, respectively.

III. RESULTS AND DISCUSSION

The descriptive parameters of the samples observed under both conditions are determined using equations (1), (2), (3) and (4). The results obtained are given in Table II below:

TABLE II
SAMPLE PARAMETERS

Parameters	Sample 1	Sample 2	Units
\bar{i}	0.161	0.108	mA
n	90	90	
s^2	0.00403	0.00427	
SE	0.0131	0.0135	

In the bid to disprove the null hypothesis and ultimately validating the alternative hypothesis, the estimated parameters of the two populations calculated above are substituted in equation (7) to obtain the test statistic value. Figure 2 depicts the rejection regions of the null hypothesis of which the boundaries are marked by the z value.

The obtained z value falls beyond the critical values in both directions of the two-tailed or bidirectional test. The

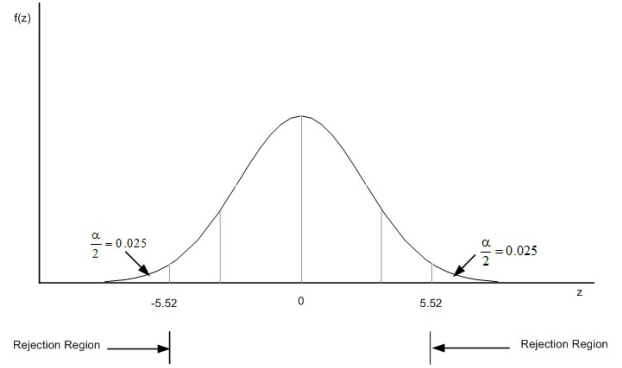

Fig. 2. Rejection Regions for a two-tailed test with $\alpha = 0.05$.

null hypothesis did not meet the test condition discussed above, and can therefore be rejected. This implies that the hypothesised value assigned to the difference between the mean THC of the two populations in the beginning of the test cannot be located within the confidence intervals at 0.05 significance level. Equations (10) and (11) could be applied to determine the confidence limits of the mean THC. Relation (9) can now be written as follows:

$$0.0342 \leq (\bar{i}_1 - \bar{i}_2) \leq 0.0718$$

Both the lower and upper confidence limits thus obtained are proven to be higher than the hypothesised value at 95 % confidence. To determine the confidence interval in which the percentage deviation or difference between the means of the two populations, relation (12) is invoked. This yields the following:

$$31.7\% \leq \frac{\bar{i}_1 - \bar{i}_2}{\bar{i}_2} \times 100 \leq 66.5\%$$

The hypotheses formulated for testing purposes in this work point to the analysis of the impact of 5 % content of third harmonic in the voltage supply on the THC-based assessment of MOV arresters. The null hypothesis supposed no effect whatsoever whereas the alternative hypothesis claimed a THC increase or decrease. The sample means used to estimate the populations under study are within $\pm 1.4\%$ of ME, which is an indication of good sampling. The rejection of the null hypothesis implies that the presence of distortion on the supply voltage will ultimately inflate or deflate the mean THC of the concerned population.

Furthermore, the estimation of the confidence interval in which lies the percentage deviation of the mean THC of the population observed under distortion is determined at 95 % confidence. These two observations are sufficiently supportive of the alternative claim. A closer look to the confidence limits obtained reveals that the difference of the population means is higher than zero. However, this tends by no means to imply that such a difference can never be less than zero, since a

negative difference could be interpreted as negative growth and will technically lead to the same test conclusion as conducted with positive difference of the sample means.

[7] W. Mendenhall, R. Beaver and B. Beaver. *A Brief Introduction to Probability and Statistics*, Duxbury, USA, 2002.

IV. CONCLUSION

Condition assessment of MOV arresters still requires leakage current measurement. However extracting the informative resistive component from the leakage current is not always easily achievable. The trend in industry is to indirectly measure the THC of the leakage current. However the prevalence of harmonics in electrical systems renders this method quite challenging as a result of supply voltage distortion negatively affecting the THC measurement.

For the purpose of this study, ninety low voltage varistor samples are subjected to sinusoidal and distorted supply waveforms. In each case, the mean THC is measured. The large-sample statistical test of hypothesis methodology is applied to estimate the difference between the mean THC obtained under both observations. The results obtained suggest over 95% confidence the following:

1. The THC measured on similar MOV arresters, before and after 5% injection of third harmonic content in the supply voltage, is very unlikely or simply improbable.

2. For 5% third harmonic content in the supply voltage, the percentage deviation in the THC measurement is estimated to be between 32% and 67%.

3. The knowledge of the distortion level in the supply voltage and the percentage deviation in the THC measurement could be beneficiary in determining the interval limits in which the true value of the MOV THC lies. This enables the actual condition of the MOV arrester to be estimated.

REFERENCES

- [1] V. Larsen and K. Lien, *In-service Testing and diagnosis of gapless metal oxide surge arresters*, Proceedings: 9th International Symposium on Lightning Protection, Foz do Iguacu, November 2007.
- [2] Z. Malek; Novizon and Aulia, *A New Method to Extract the Resistive Component of the Metal Oxide Surge Arrester Leakage Current*, 2nd IEEE International Conference on Power and Energy, Johor Baharu, Malaysia, December 2008.
- [3] V. Hinrichsen. *Monitoring of High Voltage Metal Oxide Surge Arresters*, 6th International Conference On Electrical Insulation, Bilbao, Spain, 1997.
- [4] M. Jaroszewsky, P.Kostyla, and K. Wieczorek. *Effect of voltage harmonics content on arrester diagnostic result*, ICSD, Toulouse, July, 2004.
- [5] IEC International Standard 60099-5. *Surge arresters-Part 5, Selection and Application recommendations. Edition 1.1, 2000-3.*
- [6] P. Bokoro, I.Jandrell, and M. Hove. *A Frequency-Domain Analysis of Varistor Current under Distorted Supply Voltage*, SAUPEC 14, Durban, South Africa, January, 2014.