

Reconfiguration and Load Balancing in the LV and MV Distribution Networks for Optimal Performance

Mukwanga W. Siti, Dan Valentin Nicolae, Adisa A. Jimoh, *Member, IEEE*, and Abhisek Ukil

Abstract—To get the distribution network to operate at its optimum performance in an automated distribution system reconfiguration was been proposed and researched. Considering, however, that optimum performance implies minimum loss, no overloading of transformers and cables, correct voltage profile, and absence of phase voltage and current imbalances, network reconfiguration alone is insufficient. It has to be complemented with techniques for phase rearrangement between the distribution transformer banks and the specific primary feeder with a radial structure and dynamic phase and load balancing along a feeder with a radial structure. This paper contributes such a technique at the low-voltage and medium-voltage levels of a distribution network simultaneously with reconfiguration at both levels. While the neural network is adopted for the network reconfiguration problem, this paper introduces a heuristic method for the phase balancing/loss minimization problem. A comparison of the heuristic algorithm with that of the neural network shows the former to be more robust. The approach proposed here, therefore for the combined problem, uses the neural network in conjunction with a heuristic method which enables different reconfiguration switches to be turned on/off and connected consumers to be switched between different phases to keep the phases balanced. An application example of the proposed method using real data is presented.

Index Terms—Distribution automation, distribution control, heuristic algorithm, load balancing, neural network, optimal control, phase arrangement, phase current imbalance, phase voltage imbalance, power loss, reconfiguration.

I. INTRODUCTION

ONE OF THE anticipated main benefits of a distribution system automation project is to get the distribution network operating at its optimum performance. Ultimately, this means that in its continuous operation a distribution network has built in it means to automatically ensure that its operations is at the optimum efficiency at the MV and LV levels; cases of overloading of transformers and cables are automatically sensed and remedied; voltage profiles along the feeders are continuously automatically kept within statutory level; and cases of phase voltage and current unbalances, inherent as loads are switched and breakers are operated, are automatically sensed and corrected. Towards this end distribution feeder reconfiguration had been proposed and researched [1]–[5], [10]–[15]. As reconfiguration alone is insufficient it has to be complemented with techniques for phase rearrangement between the distribution transformer banks and the specific primary feeder with a radial structure [2]. Even then this too is insufficient; it needs to be complemented with some sort of technique for ensuring

continuous dynamic load balancing along a feeder with a radial structure. This paper contributes such a technique at the LV level of a distribution network in simultaneity with reconfiguration at the MV level.

During normal operating conditions, an important operation problem in configuration management is network reconfiguration. As operating conditions change, the main reasons to reconfigure a network are 1) to reduce the system real power losses and 2) to relieve overloads in the network [1]. It can also be used for the networks reconfiguration management operation to restore service to as many customers as possible during a restorative state following a fault.

Many studies have been carried out on network and feeder reconfiguration in the past [1]–[5], [7], [8], [10]–[15]. Most of these were mainly directed at the primary distribution systems. The problems were formulated and solved to control the switching of sectionalize and tie switches so as to achieve a better efficiency. However, they did not guarantee the optimal solution although they provide high quality suboptimal solution. In this paper, the focus is on phase and load balancing at the primary and secondary levels of a distribution system.

Traditionally, to reduce the unbalance current in a feeder the connection phases of some feeders are changed manually after some field measurement and software analysis. This is, however, time-consuming, necessitates service interruption, and unsuccessful many times.

With the advent of artificial intelligence, telecommunication and power electronics equipments in power systems, it is becoming easier to envisage automation of the phase and load balancing problem. The automation implementation will be technically advantageous as well as economical for the utilities and the customers, in terms of the variable costs reduction and better service quality, respectively.

While neural network is adopted for the network reconfiguration problem, this paper introduces a heuristic method for the phase balancing/loss minimization problem. Comparison of the heuristic algorithm with that of the neural network shows the former to be more robust. The approach proposed here, therefore for the combined problem, uses the neural network in conjunction with a heuristic method which enables the different reconfiguration switches to be turned on/off and also connected consumers to be switched between different phases to keep the phases balanced. An application example of the proposed method using real data is presented.

II. PROBLEM DESCRIPTION AND FORMULATION

A. Network and Feeder Reconfiguration

The distribution system is the final stage in the transfer of power to individual customers. Typically, it commences from

Manuscript received July 26, 2006; revised January 12, 2007. This work was supported by Eskom, South Africa under TESP. Paper no. TPWRD-00418-2006.

The authors are with the Electrical Engineering Department, Tshwane University of Technology, Pretoria 0116, South Africa (e-mail: willysiti@yahoo.com; danaurel@yabo.co.za; jimohaa@tut.ac.za; abhiukil@yahoo.com).

Digital Object Identifier 10.1109/TPWRD.2007.905581

the secondary of the sub-transmission station transformers, and normally consists of two levels – primary distribution or medium voltage (MV) level, and the secondary distribution or low voltage (LV) level.

There are two types of switch in primary distribution systems: normally closed switch which connects line sections, and normally open switch on the tie-lines which connects two primary feeders, or two substations or loop-type laterals. Network reconfiguration (or feeder reconfiguration) is the process of altering the topological structures of the distribution feeders by changing the open/close status of the sectionalizing and tie switch [1].

In general, distribution loads show different characteristics according to their corresponding distribution lines and line sections. Therefore, load levels for each time period can be regarded as nonidentical. In the case of a distribution system with some overloaded and some lightly loaded branches, there is the need to reconfigure the system such that loads are transferred from the heavily loaded to less loaded feeders. The maximum load current which the feeder conductor can take may be considered as the reference. Nevertheless, the transfer of load must be such that a certain predefined objective is satisfied. In this case, the objective is to ensure the network has minimum real power loss. Consequently, reconfiguration may be redefined as the rearrangement of the network such as to minimize the total real power losses arising from line branches. Mathematically, the total power loss can be expressed as follows [7]–[9]:

$$P_{Loss} = \sum_{i=1}^n r_i \frac{P_i^2 + Q_i^2}{|V_i|^2} \quad (1)$$

where r_i , P_i , Q_i , V_i are, respectively, the resistance, real power, reactive power, and voltage of branch i , and n is the total number of branches in the system. The aim of this study is to minimize the power loss represented by (1) subject to the following constraints.

- The voltage magnitude of each node of each branch \mathbf{V}_j must lie within a permissible range. Here a branch can be a transformer, a line section or a tie line with a sectionalizing switch

$$\mathbf{V}_j^{\min} \leq |\mathbf{V}_j| \leq \mathbf{V}_j^{\max}. \quad (2)$$

- The line capacity limits.

B. Phase and Load Balancing

In South Africa, a distribution feeder is usually a three-phase, four wire system. It can be radial or open loop structure. The size of the conductor for the entire line of the feeder is the same. The feeder example shown in Fig. 1 has three phase conductors for the section between the main transformer and the different load points. In this study the number of loads is limited to fifteen load points. To improve the system phase voltage and current unbalances, it will require that, at the MV level, the connection between the specific feeder and the distribution transformers should be suitably rearranged. Whereas at the LV level, the assignation of single phase loads to phases along a radial feeder should also be reorganized [6]. In this work, the former is referred to as phase balancing, while the latter is generally referred to as load balancing. The ensuing benefits will be reduced loss and better performance of the network.

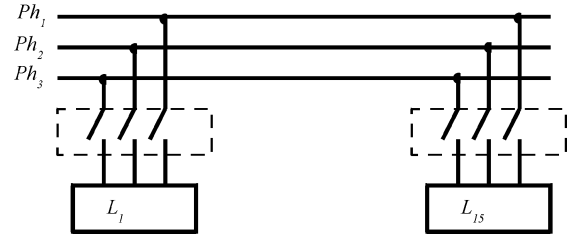

Fig. 1. Example of distribution feeder.

To balance the three phase currents in every segment and then depressing the neutral line current is a very difficult task for the distribution engineers considering the fact that they do not have control over their customers. Traditionally, phase and load balancing are done manually. Based on expert knowledge, this is usually done by changing the connection phases of a few critical distribution points to the specific primary feeder by measuring the three phase currents of the transformers. The balance of a feeder, in which the connection phases of some distribution systems are rearranged, might be improved but usually the change do not last for a long period of time. It is a matter of fact that the possibility of finding a good connection scheme to keep the phase to be balanced is almost impossible by using only the trial and error approach. Using this manual trial and error technique, interruption of the service continuity is unavoidable when changing the connection phases of distribution transformers to the feeder.

The relationship per phase between no-load voltage (\mathbf{V}_{0j}), internal impedance (\mathbf{Z}_j) and load current (\mathbf{I}_j) is shown in (3), where \mathbf{V}_j , \mathbf{I}_j and \mathbf{Z}_j are complex phasors and $j = 1, 2, 3$.

$$\mathbf{V}_j = \mathbf{V}_{0j} - \mathbf{Z}_j \mathbf{I}_j. \quad (3)$$

Given the above dependency between voltage and load current and the fact that the impedance is constant, this study will focus on the currents. Due to topology of the switch selector, Fig. 2, there could be a constraint on the number of switch-on and switch-off. Fig. 2 shows that each consumer is a single-phase load, which via a controllable static switch (in this case triac) can be connected to a desired phase. Thus, the controllable static switch enables the ensuing control action from the solution algorithm to be implemented such that a load is reconnected to a desired phase that will result in better phase balance.

For the distribution system as shown in Fig. 1, a network with three phases with a known structure, the problem consists of finding a condition of balancing. The mathematical model can be expressed as

$$\mathbf{I}_{ph1k} = \sum_{i=1}^3 sw_{k1i} \mathbf{I}_{ki} + \mathbf{I}_{ph1(k-1)} \quad (4)$$

$$\mathbf{I}_{ph2k} = \sum_{i=1}^3 sw_{k2i} \mathbf{I}_{ki} + \mathbf{I}_{ph2(k-1)} \quad (5)$$

$$\mathbf{I}_{ph3k} = \sum_{i=1}^3 sw_{k3i} \mathbf{I}_{ki} + \mathbf{I}_{ph3(k-1)} \quad (6)$$

where \mathbf{I}_{ph1k} , \mathbf{I}_{ph2k} and \mathbf{I}_{ph3k} represent the currents (phasors) per phase (1, 2, and 3) after the k point of connection; $sw_{k11} \dots sw_{k33}$ are different switches (the value of “1” means

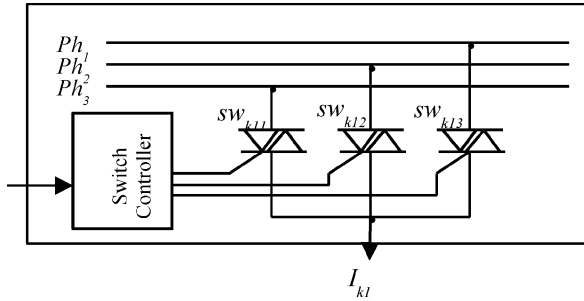

Fig. 2. Switch selector.

the switch is ON and “0” means it is OFF). I_{k1} , I_{k2} and I_{k3} represent different load currents (phasors) connected to the distribution system at point k of connections. The constraints on the switches in (4)–(6) can be written as

$$\sum_{i=1}^3 sw_{k1i} - 1 = 0 \quad (7)$$

$$\sum_{i=1}^3 sw_{k2i} - 1 = 0 \quad (8)$$

$$\sum_{i=1}^3 sw_{k3i} - 1 = 0. \quad (9)$$

III. HEURISTIC METHOD

A. Description

For the phase and load balancing a heuristic method is proposed in this paper on the sample distribution system shown in Fig. 1 which consists of 15 loads, each having three switches to the three phases. Following (7)–(9), the logic of load connection should be that: for each load, only one switch should be closed, other two should remain open, i.e., each load should be connected to only one of the three phases. The load currents are referred here by the term “load.” The following initial assumptions should be considered for the proposed method.

- i. The present algorithm should be applied to 15 loads only.
- ii. The loads should be considered equally distributed per phase, i.e., 5 loads to be connected per phase.

The problem, therefore, is: to find the optimum three sets of five loads, with minimum differences among the individual sums of the three sets. To achieve this, first we calculate the ideal phase balance current value I_{ideal} , which is equal to the one-third of the sum of the all 15 load currents I_L

$$I_{ideal} = \frac{1}{3} \sum_{j=1}^{15} I_{L_j}. \quad (10)$$

In the second step, optimally select 3 sets of currents for the three phase currents I_{ph} , each set comprising of 5 load currents $\{I_j, j = 1, \dots, 5\}$

$$I_{Load} = \{I_{L_j}, j = 1, \dots, 15\}, \quad (11)$$

$$I_{ph} = \{I_j, j = 1, \dots, 5\} \quad \text{where } I_j \in I_{Load}. \quad (12)$$

Difference between the individual sum of these sets and the I_{ideal} should be *minimum*, ideally 0 for the perfect phase balance. So, three sets of $\{I_j, j = 1, \dots, 5\}$ have to be found,

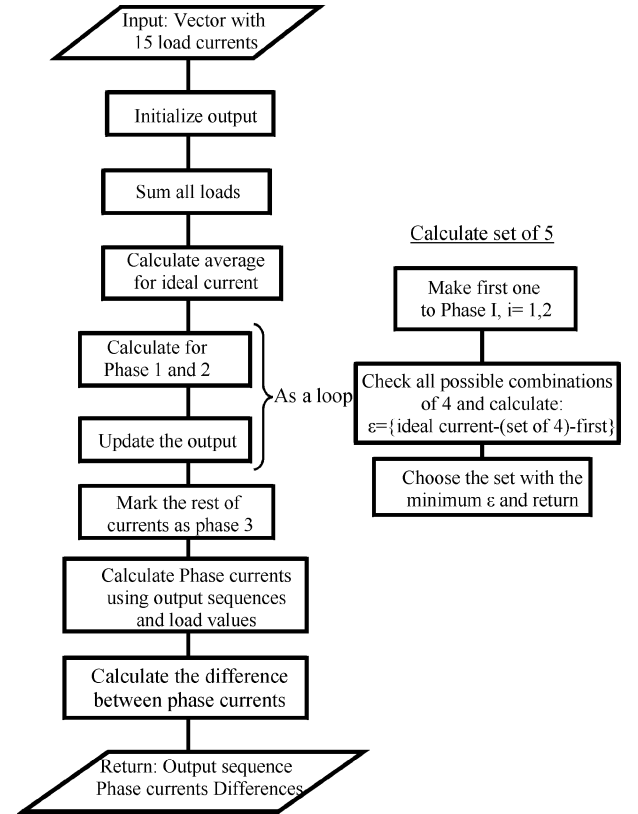

Fig. 3. Flowchart of the implementation of the heuristic method for load balancing.

subject to the constraint:

$$\min \left| \sum_{j=1}^5 I_j - I_{ideal} \right|, \quad \text{where } I_j \in I_{Load}. \quad (13)$$

The proposed heuristic method has been implemented using Matlab® [8]. The implementation takes as input the sequence of 15 load currents. It returns as output the sequence of the switch closing for each load, i.e., integer 1, 2, or 3 for each load, where 1, 2, 3 represents the switches for the respective phases as shown in Fig. 1. Using the output switch closing sequence and the load currents, we can calculate the three balanced phase currents and the differences between them, which indicate the quality of the phase balance. The implementation steps are depicted in the flowchart shown in Fig. 2.

In Fig. 3, the left chart shows the main algorithm, and right chart shows a subroutine which is explained gradually below.

B. Main Algorithm

The main algorithm for the implementation of the heuristic method is shown in the left flowchart in Fig. 3. The sequential steps are as follows.

- The 15 load currents are considered as vector.
- The output vector of the switching sequences is initialized for each load, which is also a vector of 15 elements.
- Then the I_{ideal} is computed using (10).

- Check all the 15 loads to find the *first* set of five load currents, i.e., for I_{ph1} optimally ON to I_{ideal} . This is done by the subroutine “Calculate set of 5” shown in the right chart in Fig. 2, and explained later.
- The output switching sequence for I_{ph1} is updated by marking it “1.”
- Then remaining 10 loads are checked to find the second set of 5 load currents, i.e., for I_{ph2} optimally ON to I_{ideal} . This is also done by the subroutine: “Calculate set of 5.”
- The output switching sequences for I_{ph2} is updated by marking those 2.
- After finding the sequences for I_{ph1} and I_{ph2} the rest 5 load currents will be allocated to I_{ph3} .
- The output switching sequences for I_{ph3} will be updated by marking those 3.
- The output switching sequences for I_{ph3} will be updated by marking those 3.
- Using the output switching sequences of 1, 2, 3 for I_{ph1} , I_{ph2} and I_{ph3} and the input load currents, the balancing between phase currents I_{ph1} , I_{ph2} , and I_{ph3} is computed. For example, I_{ph1} is calculated by adding all the 5 load currents corresponding to the output switching sequences marked 1.
- Then the differences between I_{ph1} , I_{ph2} and I_{ph3} is calculated which ideally should be zero. It indicates the quality of the phase balance.

• The program returns:

- i. The output switching sequence;
- ii. The phase currents I_{ph1} , I_{ph2} and I_{ph3} ;
- iii. The differences between the phase currents.

C. Subroutine

The subroutine “Calculate set of 5” used to choose the output sequences for I_{ph1} and I_{ph2} is presented; the sequential steps are:

- For I_{ph1} , we start with the 15 load currents.
- Mark the first element as 1.
- Iterate over 14 load currents for every possible combinations of the set of 4 load currents. The elements in the sets are placed position independently, i.e., {1, 2, 3, 4} is same as {2, 1, 4, 3}.
- For each possible set, the difference parameter (ε) is calculated:

$$\varepsilon = I_{ideal} - \sum \text{set of 4 currents} - \text{first current.} \quad (14)$$

- Choose the set with the *minimum* value of ε as the optimum balance set.
- We return the set for the I_{ph1} .
- For I_{ph2} , start with the 10 load currents.

- We mark the first element as 2.
- Iterate over nine load currents for every possible combinations of the set of four load currents. The elements in the sets are placed position independently, i.e., {1, 2, 3, 4} is same as {2, 1, 4, 3}.
- For each possible set, the difference parameter (ε) is calculated with (14).
- Choose the set with the *minimum* value of ε as the optimum balance set.
- Return the set for the I_{ph2} .

IV. NEURAL NETWORK

Neural network is applied to solve the network and feeder re-configuration problem. This has already been well documented by Salazar, Gallego and Romero [13], as well as Kim *et al.* in [14]. However, for comparison with the heuristic method neural network is applied here to solve the phase and load balancing problem as well.

The proposed strategy is to use the neural network to control the switch-closing sequence of each load for the minimum power loss which will lead to the optimal phase balance. The inputs to the neural network are the unbalanced load currents (fifteen in the current study) and the outputs are the switch closing sequences for each load.

The input layer of the network has N input neurons, N being the number of unbalanced load currents to be controlled.

The following column vector has been assumed as the input

$$C = [I_{L1} \dots I_{L2}]^T. \quad (15)$$

The output of the network is in the range {1, 2, 3} for each load, i.e., which switch (to the specific phase) should be ON for that specific load and moment in time.

A. Neural Network Structure

The radial basis network [3] has been used for this application. Experimentations with the back propagation and the radial basis network indicated faster training and better convergence for the latter. Radial basis networks may require more neurons than the standard feed-forward back propagation networks, but often they can be designed in a fraction of the time needed to train the standard feed-forward networks. They work best when many training vectors are available [4]. Matlab[®] neural network toolbox [8] has been used for the implementation. As result of repeated simulations with different kinds of radial basis networks, the generalized regression neural network (GRNN) [8] produced the best result; a generalized regression neural network is often used for function approximation. It has a radial basis layer and a special linear layer.

B. Network Training

The neural network was trained using 500 set of real historical data for fifteen randomly selected houses in a South African city. The real data set consisted of unbalanced load data that include average load current values per house in a specific locality of the city for the different times of each day in a month.

Assuming the number of loads to be equally distributed per phase, the problem is to find the optimum three sets of two loads, with *minimum* differences among the individual sums of the three sets. To achieve this, the ideal phase balance current value I_{ideal} is firstly calculated, which is equal to the one-third of the sum of the all 15 load currents I_L

$$I_{ideal} = \frac{1}{3} \sum_{j=1}^N I_{L_j}. \quad (16)$$

In the second step, we optimally select our 3 sets of currents for the three phase currents I_{ph} , each set comprising of two load currents $\{I_j, j = 1, \dots, n\}$.

$$I_{Load} = \{I_{L_j}, j = 1, \dots, N\} \quad (17)$$

$$I_{ph} = \{I_j, j = 1, \dots, n\} \quad \text{where } I_j \in I_{Load}. \quad (18)$$

The difference between the individual sum of these sets and the I_{ideal} should be *minimum*, ideally 0 for the perfect phase balance. So, it is needed to find three sets of $\{I_j, j = 1, \dots, n\}$, subject to the constraint

$$\min \left| \left(\sum_{j=1}^n I_j \right) - I_{ideal} \right|, \quad \text{where } I_j \in I_{Load}. \quad (19)$$

Following this, the output switching sequences are obtained as the target data set for training the networks. The balanced phase currents I_{ph1} , I_{ph2} and I_{ph3} have been computed using the output switching sequences and the input load currents. For example, I_{ph1} is calculated by adding the two load currents corresponding to the output switching sequences marked "1." Then the differences between I_{ph1} , I_{ph2} and I_{ph3} have been computed, which ideally should be zero. The differences indicate the quality of the phase balance [1].

The above-mentioned neural network is then trained using the real and simulated unbalanced load as the input vector, and the output switching sequences as the target vector. Then, the network is tested with different unbalanced load data set. The output was the optimal switching sequences of $\{1, 2, 3\}$ for the three-phases as explained above. Using the similar procedure as explained above, the balanced phase currents have been computed and the differences between the phase currents (ΔI) and the results indicate the quality of the balance

$$\Delta I_{\max} = \max\{||I_{ph1}|| - ||I_{ph2}||, ||I_{ph2}|| - ||I_{ph3}||, ||I_{ph3}|| - ||I_{ph1}||\}. \quad (20)$$

V. SIMULATION RESULTS

First, the algorithm was tested on real data, received from local electricity supply. This data set had average load current values per consumer in a specific locality of the city for different times of each day in a month. The same fifteen consumers, which historical data were used to train the neural network, have been selected as case study. The load currents were measured three times at different time period of the day and the results are as presented in Table I, where "1" means the respective load is connected to Ph_1 , "2" to Ph_2 and "3" to Ph_3 . These data with

TABLE I
UNBALANCE LOAD CURRENTS (DATA)

Consumer	1 ST Data Set		2 ND Data Set		3 RD Data Set	
	I_L (A)	[Sw]	I_L (A)	[Sw]	I_L (A)	[Sw]
1	94.06	1	40.16	1	1.51	1
2	22.88	2	92.61	2	73.93	2
3	60.07	3	90.77	3	44.06	3
4	48.11	1	40.61	1	92.24	1
5	88.23	2	88.47	2	46.13	2
6	75.44	3	5.73	3	41.44	3
7	45.19	1	34.93	1	83.77	1
8	1.83	2	80.50	2	51.99	2
9	81.31	3	0.97	3	20.06	3
10	60.92	1	13.75	1	66.54	1
11	78.40	2	20.07	2	82.97	2
12	91.25	3	19.67	3	1.94	3
13	73.08	1	59.77	1	67.44	1
14	17.45	2	26.94	2	37.56	2
15	44.02	3	19.68	3	82.34	3
<i>Phase Current Summary</i>						
I_{ph1} (A)	321.36		189.22		311.5	
I_{ph2} (A)	208		301.23		252.58	
I_{ph3} (A)	260.84		143.58		189.84	
$\Delta I_{ph-\max}$ (A)	113.36		157.65		121.66	

TABLE II
OUTPUT SWITCHING SEQUENCES

Switching seq. for 15 loads	1 ST Data Set		2 ND Data Set		3 RD Data Set	
	NN	HE	NN	HE	NN	HE
1	1	1	1	1	1	1
2	2	2	2	1	2	2
3	1	1	3	2	3	3
4	3	3	1	3	1	2
5	1	3	3	3	1	1
6	1	3	1	1	2	2
7	2	2	3	3	3	3
8	3	3	1	2	1	1
9	2	3	2	2	3	2
10	1	1	1	1	2	3
11	3	2	3	2	2	1
12	2	1	2	2	3	3
13	2	2	3	1	1	3
14	2	2	2	3	1	2
15	1	1	2	3	1	1

the original unbalance are adopted as the base for validating the two algorithms.

An Intel® Celeron® 1.9 GHz, 256 MB RAM computer was used for the test and the algorithms were implemented using Matlab 6. Table II shows the output switching sequences for the two algorithms. Table III shows the results of applying the two algorithms indicating ensuing balanced phase currents. In Tables II and III, "NN" is the abbreviation for the Neural Network-based approach, and "HE" is the abbreviation for the Heuristic Method based approach.

Table III shows the phase currents to the transformer connection after applying NN and HE. The parameter $\Delta I_{Ph-\max}$ in Tables I, III, and IV is the maximum difference of the phase currents, which ideally should be zero if there is no imbalance.

To confirm the general applicability of the methods and the resulting comments the test was repeated for a bigger system of 45 loads. The results are as presented in Table IV.

TABLE III
BALANCE PHASE CURRENTS

	1 ST Data Set		2 ND Data Set		3 RD Data Set	
	NN	HE	NN	HE	NN	HE
I_{ph1} (A)	270.9	290.8	175.5	208.3	299.6	262.3
I_{ph2} (A)	304.1	299.5	245.2	210.6	227.4	267.9
I_{ph3} (A)	307.3	291.9	213.9	215.8	266.9	263.7
ΔI_{phmax} (A)	36.4	8.7	69.7	7.5	72.2	5.6
T_c (sec)	0.17	0.14	0.17	0.14	0.17	0.14

A. Comments on Results

- Comparing the parameter ΔI_{Ph-max} , the maximum difference of the phase currents, in the unbalance situation (Table I) with those obtained after applying the two algorithms (Table III), a considerable improvement in the unbalance is noted, and the Heuristic algorithm appears to give a better phase balancing result. This observation is confirmed also for a bigger system in Table IV.
- In terms of the average computation time (T_c), as can be noticed from Tables III and IV, the heuristic method is faster compared to the neural network method. The difference seems to increase with bigger number of loads.
- The proposed methods and their resulting comments are generally applicable to any number of unbalanced load data or system.

VI. CONCLUSIONS

Phase and load balancing are important complement to network and feeder reconfiguration. In distribution automation these problems have to be continuously solved simultaneously to guarantee optimal performance of a distribution network. In this paper the phase balancing problem between the specific feeder at MV level and the distribution transformers in a radial structure, and the load balancing along a LV feeder have been formulated as current balancing optimization problems with due consideration for the various constraints. On the other hand the network and feeder reconfiguration problem was formulated as power loss minimization problem with the view for its solution to control the opening and closing of sectionalizing and tie switches.

Emphasis has been concentrated on solving the phase and load balancing problems, as it appears the solution of the reconfiguration problem has been well covered in the literatures. Two Matlab[®] based solution methods have been proposed and demonstrated with real data. The first is a heuristic method and the other is neural network-based technique. The proposed methods were successfully tested using real data obtained from local municipal electricity supplier. From practical point of view these methods can be very effective as several model-based approaches usually take very long running time. The heuristic method has been found to be more suitable and faster compared to the neural network.

TABLE IV
45 LOADS APPLICATION

	Unbalanced		Balanced	
		Switch	NN	HE
I_1 (A)	40.16	1	1	1
I_2 (A)	92.61	2	2	1
I_3 (A)	90.77	3	3	2
I_4 (A)	40.61	1	1	3
I_5 (A)	88.47	2	3	3
I_6 (A)	5.73	3	1	1
I_7 (A)	34.93	1	3	3
I_8 (A)	80.50	2	1	2
I_9 (A)	0.97	3	2	2
I_{10} (A)	13.75	1	1	1
I_{11} (A)	20.07	2	3	2
I_{12} (A)	19.67	3	2	2
I_{13} (A)	59.77	1	3	1
I_{14} (A)	26.94	2	2	3
I_{15} (A)	19.68	3	2	3
I_{16} (A)	1.51	1	1	1
I_{17} (A)	73.93	2	2	2
I_{18} (A)	44.06	3	3	3
I_{19} (A)	92.24	1	1	2
I_{20} (A)	46.13	2	1	1
I_{21} (A)	41.44	3	2	2
I_{22} (A)	83.77	1	3	3
I_{23} (A)	51.99	2	1	1
I_{24} (A)	20.06	3	3	2
I_{25} (A)	66.54	1	2	3
I_{26} (A)	82.97	2	2	1
I_{27} (A)	1.94	3	3	3
I_{28} (A)	67.44	1	1	3
I_{29} (A)	37.56	2	1	2
I_{30} (A)	82.34	3	1	1
I_{31} (A)	94.06	1	1	1
I_{32} (A)	22.88	2	2	2
I_{33} (A)	60.07	3	1	1
I_{34} (A)	48.11	1	3	3
I_{35} (A)	88.23	2	1	3
I_{36} (A)	75.44	3	1	3
I_{37} (A)	45.19	1	2	2
I_{38} (A)	1.83	2	3	3
I_{39} (A)	81.31	3	2	3
I_{40} (A)	60.92	1	1	1
I_{41} (A)	78.40	2	3	2
I_{42} (A)	91.25	3	2	1
I_{43} (A)	73.08	1	2	2
I_{44} (A)	17.45	2	2	2
I_{45} (A)	44.02	3	1	1
I_{ph1} (A)	822.1	-	746.1	761.4
I_{ph2} (A)	809.9	-	778.5	786.1
I_{ph3} (A)	678.8	-	788.1	771.4
ΔI_{ph-max} (A)	143.3	-	42	24.7
T_c (sec)	-	-	0.49	0.39

ACKNOWLEDGMENT

The authors thank the local municipal electricity provider for the real data.

REFERENCES

- [1] S. Civanlar and J. J. Grainger, "Distribution feeder reconfiguration for loss reduction," *IEEE Trans. Power Del.*, vol. 3, pp. 1217–1223, Jul. 1988.
- [2] T. H. Chen and J. T. Chergn, "Optimal phase arrangement of distribution transformers connected to a primary feeder for system unbalance improvement and loss reduction using genetic algorithm," *IEEE Trans. Power Syst.*, vol. 15, no. 3, pp. 994–1000, Aug. 2000.
- [3] C. C. Liu, S. J. Lee, and K. Vu, "Loss minimization of distribution feeders: Optimality and algorithms," *IEEE Trans. Power Del.*, vol. 4, no. 2, pp. 1281–1289, Apr. 1989.

- [4] C. B. Alexandre, A. Carlos, and Newton, "Main chain representation for evolutionary algorithms applied to distribution system reconfiguration," *IEEE Trans. Power Syst.*, vol. 20, no. 1, pp. 206–212, Feb. 2005.
- [5] M. E. Baran and F. F. Wu, "Network reconfiguration in distribution systems for loss reduction and load balancing," *IEEE Trans. Power Del.*, vol. 7, no. 2, pp. 1401–1407, Apr. 1989.
- [6] M. Siti, A. A. Jimoh, and D. Nicolae, "Load balancing in distribution feeder through reconfiguration," presented at the IECON, Raleigh, NC, Nov. 6–12, 2005.
- [7] M. Siti and A. A. Jimoh, "Reconfiguration circuit loss minimization through feeder reconfiguration," presented at the SAUPEC Conf., Stellenbosch, South Africa, 2004.
- [8] Ukil, M. Siti, and J. Jordaan, "Feeder load balancing using neural network," presented at the Int. Symp. Neural Networks, Chengdu, China, May 28–31, 2006.
- [9] Matlab Documentation – Neural Network Toolbox MathWorks, Natick, MA, 2002, 0.180913a, Release 13, 6.5.
- [10] C. S. Chen and M. Y. Cho, "Energy loss reduction by critical switches, of distribution feeders for loss minimization," *IEEE Trans. Power Del.*, vol. 4, no. 3, pp. 1246–1253, Jul. 1992.
- [11] X. Yang, S. P. Carull, and K. Miu, "Reconfiguration distribution automation and control laboratory: Multiphase radial power flow experiment," *IEEE Trans. Power Syst.*, vol. 20, no. 3, pp. 2156–2166, Aug. 2005.
- [12] A. Auguglio, L. Dusonchet, and M. Giuseppe, "Minimum losses reconfiguration of MV distribution networks through local control of tie-switches," *IEEE Trans. Power Del.*, vol. 18, no. 3, pp. 762–771, Jul. 2003.
- [13] H. Salazar, R. Gallego, and R. Romero, "Artificial neural networks and clustering techniques applied in the reconfiguration of distribution systems," *IEEE Trans. Power Del.*, vol. 21, no. 3, pp. 1735–1742, Jul. 2006.
- [14] H. Kim, Y. Ko, and K.-H. Jung, "Artificial neural-network based feeder reconfiguration for loss reduction in distribution systems," *IEEE Trans. Power Del.*, vol. 8, no. 3, pp. 1356–1366, Jul. 1993.
- [15] T. P. Wagner, A. Y. Chikani, and R. Hackman, "Feeder reconfiguration for loss reduction: An application of distribution automation," *IEEE Trans. Power Del.*, vol. 6, no. 4, pp. 1922–1933, Oct. 1991.



Mukwanga Siti received the B.Sc. and M.Sc. degrees in electrical engineering from the University of Pretoria, Pretoria, South Africa, in 2000 and 2002, respectively.

He is with the Electrical Engineering Department, Tshwane University of Technology, Pretoria North, South Africa. His research interests include power quality, energy management, and distribution system reconfiguration.



Dan Valentin Nicolae was born in 1948 in Bucharest, Romania. He received the M.Sc. degree from the Polytechnic University of Bucharest, Bucharest, Romania, in 1971 and the Ph.D. degree from the Vaal University of Technology, Vangerbijlpark, South Africa, in 2004.

He was a Researcher with the Institute for Nuclear Technologies, National Institute for Scientific and Technological Creativity, Avionics Division, Bucharest, Romania. In 1998, he joined the Electrical Department, Tshwane University of Technology,

Pretoria, South Africa. He is conducting research in the field of power converters, control of electric machines, and nonconventional power extraction from high-voltage transmission lines.

Dr. Nicolae is a member of the Engineering Counsel of South Africa and South African Institute of Electrical Engineers.



Adisa A. Jimoh (M'86) received the B.Eng. and M.Eng. degrees from Ahmadu Bello University (ABU), Zaria, Nigeria, in 1977 and 1980, respectively, and the Ph.D. degree from McMaster University, Hamilton, ON, Canada, in 1986.

He was with ABU until 1992, when he moved to the Research and Development Unit, National Electric Power Authority (NEPA), Lagos, Nigeria. He was with NEPA until 1996 when he moved to the University of Durban-Westville, Durban, South Africa, where he taught courses and carried out

research in high-performance energy efficient electric machines and power systems and power electronics. In 2001, he joined Tshwane University of Technology, Pretoria, South Africa, where, as a Full Professor, he leads and coordinates the research and doctorate programs of the Graduate School of Electrical and Electronic Engineering. His research interests are in electric machines, drives, and power-electronics applications in power systems.

Dr. Jimoh is a Registered Engineer in South Africa.

Abhisek Ukil received the B.E. degree in electrical engineering from the Jadavpur University, Calcutta, India, in 2000 and the M.Sc. degree in electronic systems and engineering management from the University of Applied Sciences, Soest, Germany, and Bolton Institute, Bolton, U.K., in 2004. He recently completed the D.Tech. degree in the Department of Mathematical Technology, Tshwane University of Technology, Pretoria, South Africa, in 2005.