

VIBRATION ANALYSIS OF A VARIABLE LENGTH BLADE WIND TURBINE

TARTIBU, L.K.¹, KILFOIL, M.¹ and VAN DER MERWE, A.J.²

¹Department of Mechanical Engineering,
Cape Peninsula University of Technology, Box 652, Cape Town 8000, South Africa.

²School of Computing and Mathematical Sciences,
AUT University, Private Bag 92006, Auckland 1142, New Zealand

ABSTRACT

In this paper, Flap-wise, edge-wise and torsional natural frequencies of a variable length blade have been identified. Therefore designers can ensure that natural frequencies will not be close to the frequency of the main excitation forces in order to avoid resonance. The fixed portion and moveable portion of the variable length blade are approximated respectively by a hollow and a solid beam which can be slid in and out. Ten different configurations of the variable length blade, representing ten different positions of the moveable portion are investigated. A MATLAB program was developed to predict natural frequencies. Similarly three-dimensional models of the variable length blade have been developed in the finite element program Unigraphics NX5. Concurrence between MATLAB and Unigraphics NX5 results has been found for the frequency range of interest. This means that an effective method to compute natural frequencies of a variable length blade was developed.

KEYWORDS: Variable length blade, natural frequencies, vibration, finite element analysis, wind turbine.

I. INTRODUCTION

Energy is necessary for achieving sustainable development among societies. Unlike fossil energies, such as gas and coal, which contain high percentages of carbon, renewable energies consist of sources that are naturally inexhaustible - water, sun, biomass, geothermal heat, and wind [1]. Among these renewable sources, wind is considered one of the most promising types of regenerative energy to reduce fossil fuel imports and greenhouse gases. By using the resources of wind energy, we can decrease our dependence on oil and protect the planet for future generations. When "harvested" by modern wind turbines, the wind flow can be used to generate electricity.

Blades are the main components that differentiate wind turbines from other machinery, acting as the "respiratory centre" of a wind turbine. The length of the blade determines the amount of power that can be extracted from the wind, because the blade affects the swept area of the rotor. In order to attain the highest possible power output in conditions of widely varying wind speed, a variable length blade has been recently proposed. The basic concept of this variable length blade wind turbine is to attain higher energy capture in low wind conditions by increasing the blade length and to minimise mechanical loads in high wind conditions by decreasing the blade length [2]. The wind turbine blade consists of a fixed portion and a moveable blade portion, which can be slid inside the fixed portion (Figure 1).

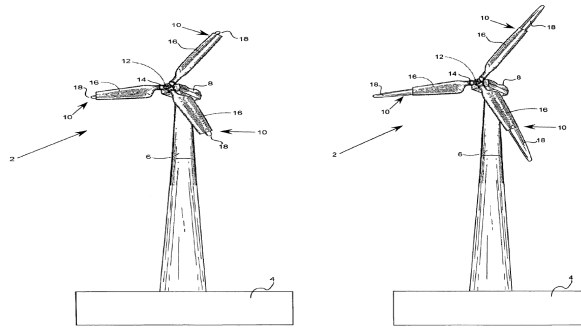

Figure 1: Wind turbine with variable length blades with the blades extended and retracted. (Adapted from [2])

Vibration is important in wind turbines, because they are partially elastic structures, and they operate in an unsteady environment that tends to result in a vibrating response. The amplitude of the generated vibrations of a wind turbine blade depends on the stiffness of the blade [3] which is a function of material, design and size. One issue a variable length blade design presents to blade designers is that of structural dynamics. A wind turbine blade has certain characteristic natural frequencies and mode shapes which can be excited by mechanical or aerodynamic forces. Variable length blade design presents additional challenges as stiffness and mass distribution change as the moveable blade portion slides in and out of the fixed blade portion.

Hence, a key to good wind turbine design is to minimize vibrations by avoiding resonance. Resonance is a phenomenon occurring in a structure when an exciting or forcing frequency equals or nearly equals one of the natural frequencies of the system [4]. It is characterized by a large increase in displacements and internal loads. Surprisingly, the dynamic stability and the absence of resonances within the permissible operating range of a variable length wind turbine have not been investigated yet. Generally, research on the turbine blades focus on vibration frequencies and mode shapes. For simplification, a cantilevered beam can be used to replace the turbine blade [5]. Knowing the geometric shape and the material properties of the blade, the natural frequencies can be estimated using finite element analysis.

Manufacturers of wind turbines are interested in studying and verifying both edge-wise and flap-wise vibrations (see Figure 2) of the turbine blade. The most visible and present source of excitation in a wind turbine system is the rotor.

- The constant rotational speed is the first excitation frequency, mostly referred to as 1P.
- The second excitation frequency is the rotor blade passing frequency: $N_b P$ in which N_b is the number of rotor blades: 2P for a turbine equipped with two rotor blades, 3P for a three-bladed rotor.

The structure should be designed such that its natural frequencies do not coincide with either 1P or $N_b P$ [6] otherwise resonance may occur in the whole structure of the turbine, leading to vibrations with increasing amplitude which may eventually destroy the whole wind turbine [4]. Therefore, flap-wise and edge-wise frequencies were calculated in the study reported here.

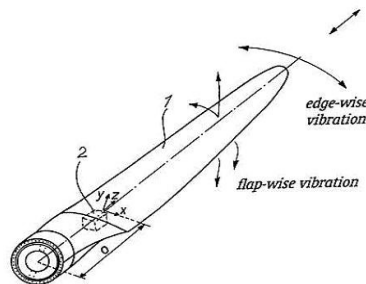

Figure 2: Edge-wise and flap-wise vibrations of the blade. (Adapted from [7])

Reduction of vibration is a good measure for a successful design in blade structure [8]. Dealing with vibration in an early phase of the design process avoids costly modification of a prototype after detection of a problem. There are two main approaches to wind turbine blade dynamics analysis. For existing blades, dynamics can be measured using experimental techniques. Although this is considered a rapid approach, it requires the experimental set-up to be available. Prediction of the blade dynamics during the design is critical where dynamics analysis is required. Finite element analysis constitutes the second approach. In the following section, finite element analysis will be used to predict the dynamics.

The rest of the paper is organised as follows: in section 2, the modelling theory and the models chosen are described. In section 3, finite element analysis is presented while the softwares used to build the models are described. In section 4 and 5, the results found using the different approaches are respectively presented and discussed thoroughly. The contextualization of the findings are presented in section 6. Finally in section 7 and 8 the concluding remarks and future works are presented.

II. MODELLING THEORY

The main objective of this work is to calculate natural frequencies of the variable length blade using commercial software. Two different methods are used for obtaining the natural frequencies:

- MATLAB program for one-dimensional finite element models;
- NX5 three dimensional models.

To validate results, the outputs from different methods are evaluated and compared.

A wind turbine blade can be seen as beam of finite length with airfoil profiles as cross-sections. A rectangular cross section representing a cross-section of the blade can give qualitatively appropriate results in a simpler way. Therefore, such a model has been adopted for this analysis. The fixed portion and the moveable portion of the variable length blade (variblade) have been approximated respectively by a hollow beam and a solid beam which can be slid in and out as shown in Figure 3.

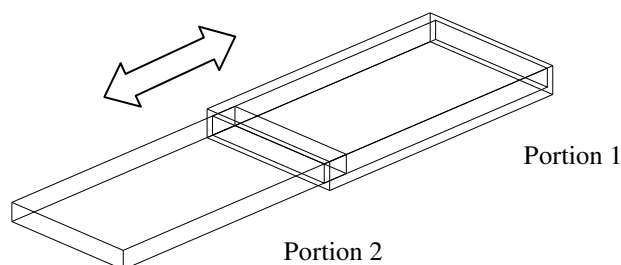

Figure 3: Variable length blade (Variblade).

Both flap-wise and edge-wise natural frequencies of the variblade have been calculated for ten different configurations. The ten different configurations depending on the position of the second portion of the variblade are represented in Figure 4. These configurations change from zero extension to full extension in ten equal steps.

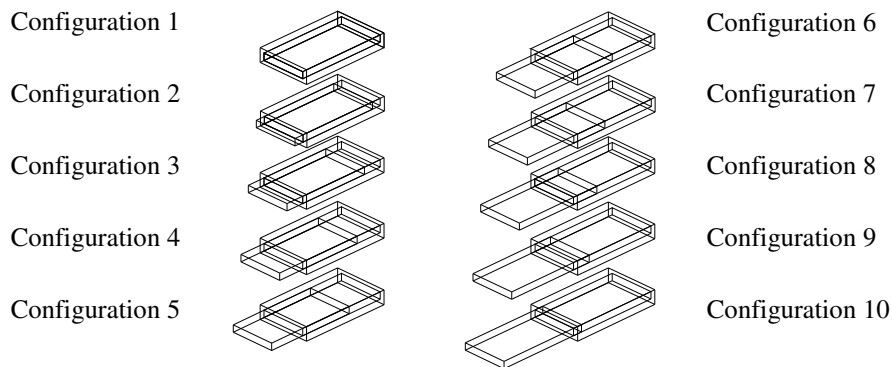

Figure 4: Ten configurations of variblade.

III. FINITE ELEMENT ANALYSIS

The goal of this analysis is to determine at what frequencies a structure vibrates once it has been set into motion. These frequencies are described as natural frequencies. In other words, natural frequency is the number of times a system will oscillate (move back and forth) between its original position and its displaced position, if there is no outside interference. These frequencies are dependent on the fundamental characteristics of the structure, such as geometry, density and stiffness. These same characteristics may be included in a finite element model of a structural component. The finite element model can be used to determine the natural modes of vibration and corresponding frequencies. Once the geometry, density and elastic material models have been defined for the finite element model, in the absence of damping, the dynamic character of the model can be expressed in matrix form as [9]:

$$KV = \omega^2 MV \quad (1)$$

Here K is the stiffness matrix, M is the mass matrix, ω is the angular frequency of vibration for a given mode and V is the mode vector that expresses the corresponding mode shape. A finite element program uses iterative techniques to determine a set of frequencies and shapes that satisfy the finite element matrix equation.

3.1. MATLAB

Although many commercial finite element codes exist which are capable of modelling the beam structure, it was decided that a code would be written within MATLAB to do all the modelling. This provides the benefit of being able to run the code on any computer using MATLAB. The basis for the MATLAB code was the one-dimensional Euler-Bernoulli beam element. A MATLAB program (VARIBLADEANALYSIS.m) has been developed for a one-dimensional model for the variblade. The geometry, material properties, vibration modes (flap-wise or edge-wise), number of elements and configuration of the variblade have been made as selectable parameters which allow analysis of blades with different sizes and properties. The program requires the following input data, supplied in an m-file:

- Beam dimensions (length of beam portions, width of hollow and solid beam, thickness of hollow and solid beam),
- material properties sets: Young's modulus, density;
- global degree of freedom;
- vibration direction (flap-wise or edge-wise);
- element definition (number of element) and,
- beam configuration (position of moveable portion).

Both flap-wise and edge-wise natural frequencies have been calculated for ten different configurations.

3.2. NX5

Three-dimensional models of all the different previous beams have been developed in the commercial finite element analysis program Unigraphics NX5. Those models are designed to capture three-dimensional behaviour. The blade has been modelled as a cantilever, therefore, is fully constrained at the end of the inboard portion (where it is attached to the turbine shaft/hub). The outputs of the simulation are the natural frequencies of vibration: flap-wise, edge-wise and torsional natural frequencies as well as their mode shapes.

One end in each model has been fully constrained. The geometrical model of the beams is meshed by using a tetrahedral mesh. Nastran-SEMODES103 has been used as solver for modal analysis. Normal modes and natural frequencies have been evaluated. Damping is not considered and loads are irrelevant. The mode shapes were identified by examining the deformation plot (flap-wise, edge-wise and torsional deformation) and by the animated mode shape display.

IV. NX5 AND MATLAB RESULTS COMPARISON FOR VARIBLADE

As explained before the variable length blade has been approximated to a variblade with two portions (Figure 3). Ten different configurations (Figure 4) depending of the position of the outboard portion were investigated. These configurations change from zero extension to full extension in ten equal steps of 100 mm. Values of the material and geometric properties of the two portion of the variblade under investigation are given in Table 1.

Table 1: Material and geometric properties of the variblade.

	Geometric properties				Material properties (Carbon fiber composite) [10]		
	$L(mm)$	$W(mm)$	$T(mm)$	$Wh(mm)$	$E(mN/mm^2)$	$\rho(kg/mm^3)$	ν
Portion1	1000	60	20	5	230×10^6	1.8×10^{-6}	0.3
Portion2	1000	50	10	N/A	230×10^6	1.8×10^{-6}	0.3

L : length	Wh : wall thickness
W : width	E : Young's modulus
T : thickness	ρ : density
	ν : Poisson's ratio

This section contains examples of the results obtained with NX5 for three different configurations of the variblade (those configurations have been selected arbitrary). Flap-wise, edge-wise and torsional deflections are represented (Figure 5, Figure 6 and Figure 7).

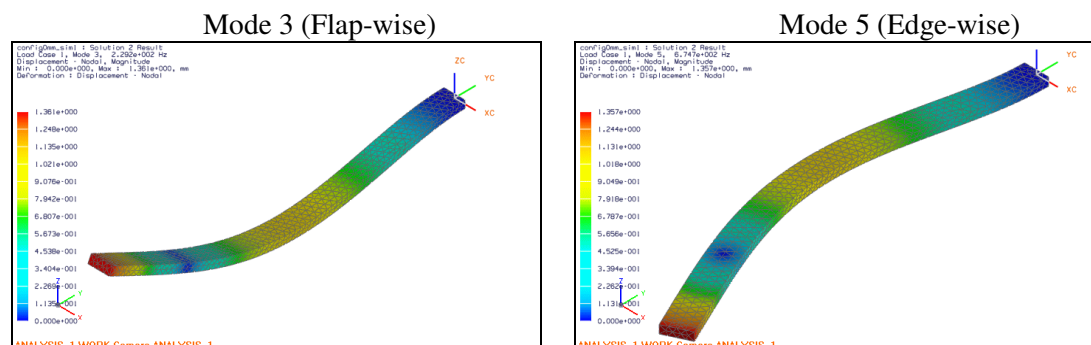

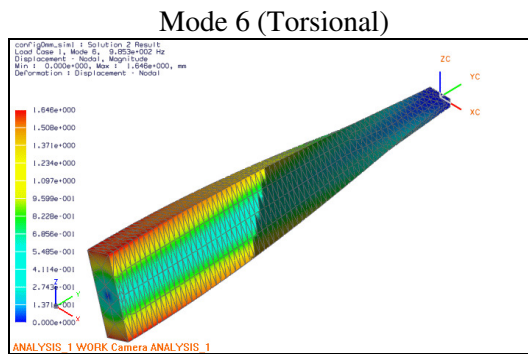

Figure 5: Flap-wise, edge-wise and torsional deflection for configuration 1

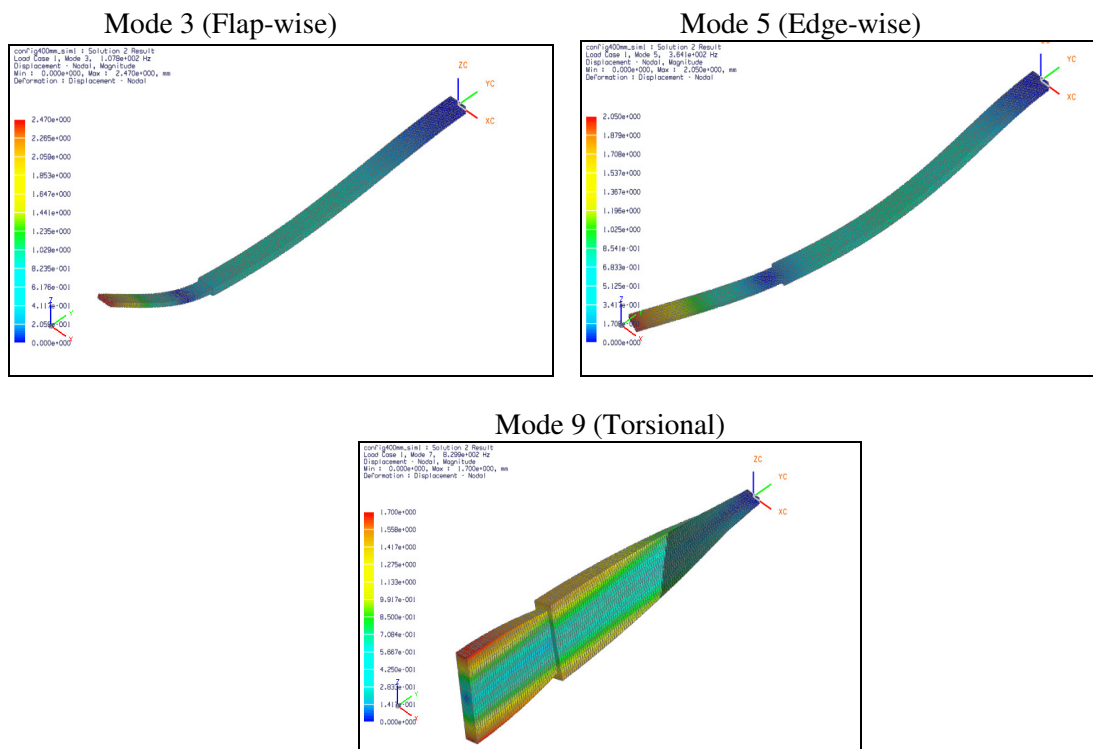
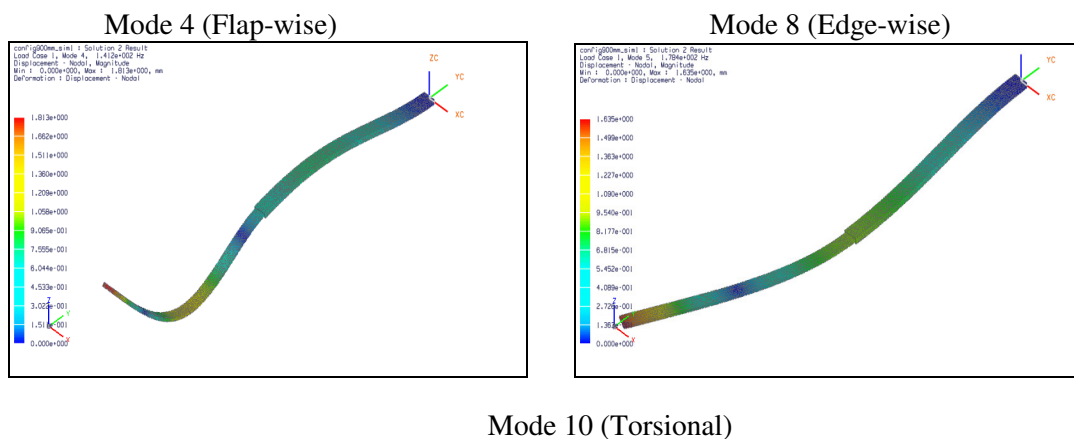

Figure 6: Flap-wise, edge-wise and torsional deflection for configuration 5



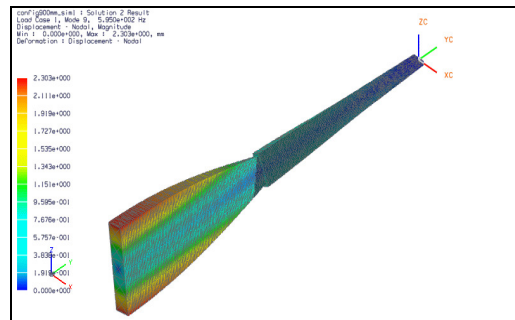

Figure 7: Flap-wise, edge-wise and torsional deflection for configuration 10

The MATLAB program VARIBLADEANALYSIS.m has been used to compute natural frequencies. The results found using this MATLAB program have been compared to those found using NX5. The first five natural frequencies (flap-wise and edge-wise) of the variblade are calculated successively for ten different configurations. Torsional natural frequencies obtained with NX5 have been ignored because the MATLAB program can calculate only flap-wise and edge-wise natural frequencies. Figure 8 represents the results obtained for configuration 1, configuration 5 and configuration 10.

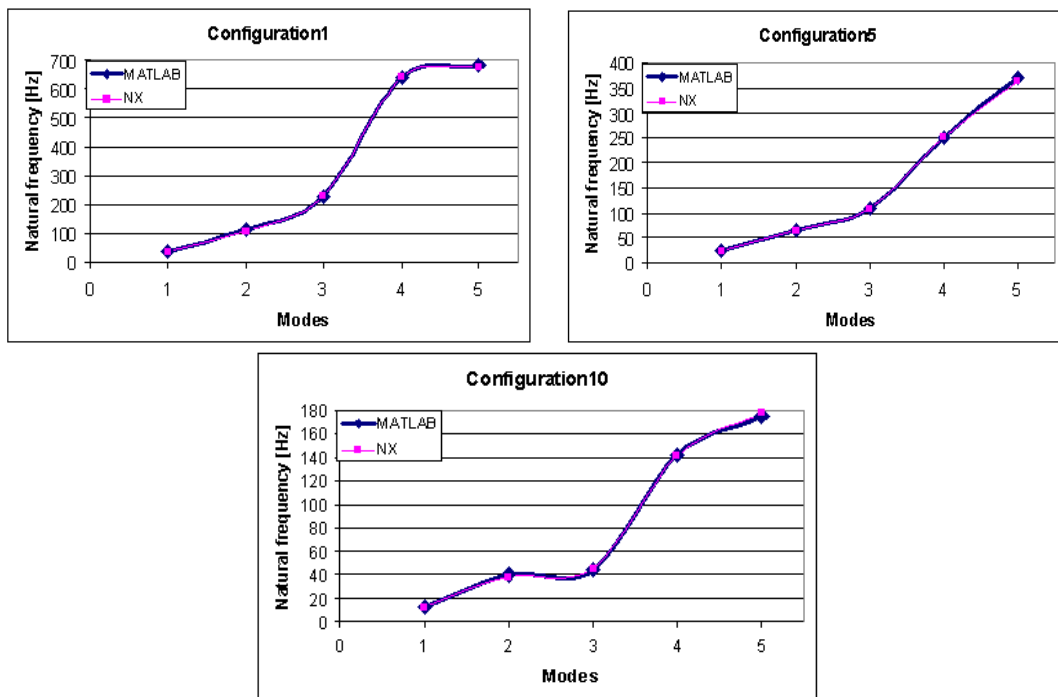

Figure 8: MATLAB and NX5 results comparison

V. INFLUENCE OF BLADE LENGTH

The influence of varying the blade length has been studied and the results are shown in Figure 9 for the first five natural frequencies related to the configurations of the variblade. Table 2 provides values of these first five natural frequencies calculated for each configuration of the variblade shown in Figure 3.

Table 2: Computed natural frequencies (NX5)

Configuration number	Computed natural frequencies (Hz)				
	Mode1	Mode2	Mode3	Mode4	Mode5
1	36.6	109	229	640	675
2	33.1	94.6	205	560	589
3	29.5	82.2	174	422	509

4	26.4	72.7	140	302	434
5	23.6	64.7	108	250	364
6	21.0	57.8	83.8	225	305
7	18.7	51.8	67.8	205	259
8	16.5	46.5	57.2	184	224
9	14.5	41.9	50.0	162	198
10	12.7	37.8	45.2	141	178

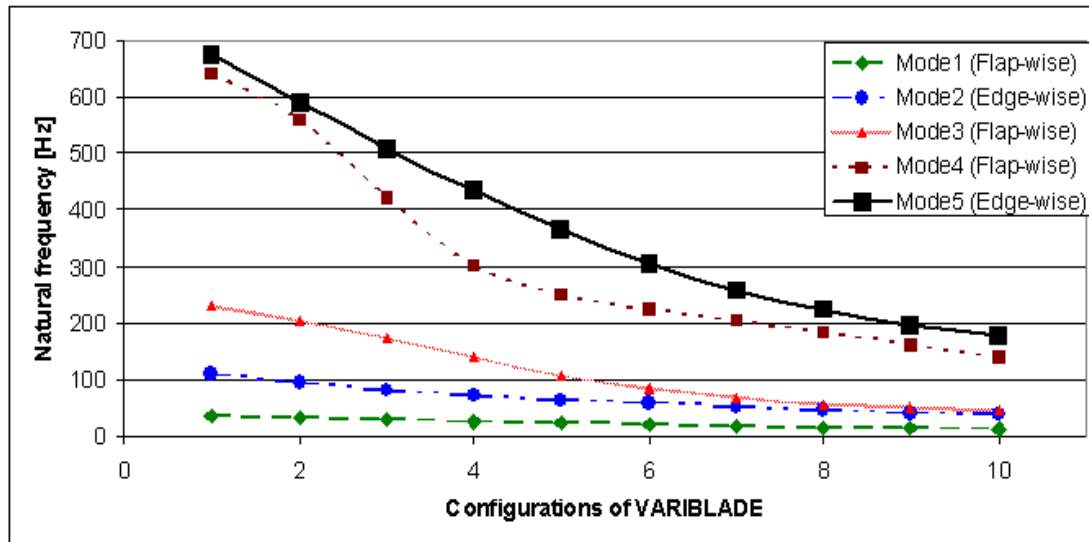

Figure 9: Natural frequencies

VI. CONTEXTUALIZATION OF THE FINDINGS

During design of a wind turbine blade, the 1st flap-wise, 2nd flap-wise, 1st edge-wise and the 1st torsional natural frequencies shall be determined as a minimum [11]. It can be seen (Figure 8) that there is good agreement between the MATLAB and NX5 results for the first five natural frequencies. It should be noted that only the frequency range between 0.5 Hz and 30 Hz [11] is of relevance to wind turbine blades. In that range, MATLAB and NX5 provide identical results. Torsional natural frequencies have been calculated using NX5. The lowest torsional natural frequency (configuration 10) determined is 595 Hz. It can be concluded that torsional natural frequencies are not a concern for this variblade model (Table 1) as they are out of the range of interest.

The study of the influence of blade length on natural frequencies represented in Figure 9 has shown that with increasing blade length, the natural frequencies decrease. This is probably because the blade becomes more flexible as its length increases. The excitation loads are concentrated in the interval 0.5 Hz-30 Hz. As shown in Table 2, mode 1 (included in the interval 12.7 Hz-36.6 Hz) may coincide with these excitation frequencies. Therefore the first mode may be subjected to excitation for this model (Table 1).

VII. CONCLUSIONS

The following expected conclusions have been drawn:

- Good agreement between NX5 and MATLAB results has been found for the frequency range of interest using a composite material variblade. Therefore both NX5 and the MATLAB program can be used to calculate natural frequencies for any other isotropic material. This means that an effective method to compute natural frequencies of a variblade was developed;
- natural frequencies are a function of configuration number and,
- increasing the blade length reduces natural frequencies.

More specifically for variblades, the following conclusions have been drawn:

- The range between 0.5 Hz and 30 Hz is of relevance to wind turbine blades. Although the first five natural frequencies have been calculated, only the first flap-wise natural frequency is of concern for this model (Table 1). Higher flap-wise natural frequencies, all edge-wise and all torsional natural frequencies are out of this range of concern.
- the first mode (included in the interval 12.7-36.6 Hz) (Table 2) may coincide with the excitation frequencies, therefore during operation this range of frequencies should be avoided for the model proposed (Table 1);

Non-obvious advantages of the variablades are the following:

- The higher the rotor speed, the smaller the blade length becomes and, therefore the higher the natural frequency is. Similarly, as the rotor speed decreases, natural frequency decreases.
- For the variblade (Table 1), it can be seen that a smaller blade size (Table 2) (configuration 1, configuration 2 and configuration 3) does not present a risk for the variblade, since those natural frequencies are out of the range of concern. Therefore, reducing the blade length reduces the chances of resonance. Although it is an obvious conclusion, it is a non-obvious benefit.
- Due to variation in blade length, natural frequency is not constant. Even if one found that the first flap-wise natural frequency is in the region of concern, that frequency is not constant, thus reducing chances of resonance.

VIII. FUTURE WORKS

- The models developed include some approximation. The results for these simplified models shows further research with a more accurate model is required since the first mode may be subjected to excitation. The blade profile needs to be taken into account for more accurate results;
- the MATLAB program was written to be applicable to different blade shapes and materials, therefore, the cross section can be taken into account for the variblade being designed and,
- the two portions of the blade have been considered as one body in finite element analysis. Further studies can be undertaken to investigate the the effect of modelling the blade with the two portions joined in a more realistic way (e.g. with gap or contact elements).

REFERENCES

- [1] Manwell, J. F., McGowan, J. G. and Rogers. A. L. (2002). “*Wind Energy Explained*”. Chichester: John Wiley & Sons.
- [2] Pasupulati, S.V., Wallace, J. & Dawson, M. (2005), "Variable length blades wind turbine", *2005 IEEE Power Engineering Society General Meeting*, pp. 2097.
- [3] Jureczko, M., Pawlak, M. & Męzyk, A. (2005), "Optimisation of wind turbine blades", *Journal of Materials Processing Technology*, vol. 167, no. 2-3, pp. 463-471.
- [4] Burton, T., Sharpe, D., Jenkins, N. & Bossanyi, E. (2004). “*Wind Energy Handbook*”. Chichester. Wiley.
- [5] Hansen, M.O.L., Sørensen, J.N., Voutsinas, S., Sørensen, N. & Madsen, H.A. (2006), "State of the art in wind turbine aerodynamics and aeroelasticity", *Progress in Aerospace Sciences*, vol. 42, no. 4, pp. 285-330.
- [6] Wallace Jr., J. & Dawson, M. (2009), "O&M strategies: wind turbine blades", *Renewable Energy Focus*, vol. 10, no. 3, pp. 36,38,40-41.
- [7] Grabau, P. & Petersensvej, H.C. (1999). “Wind turbine with stress indicator”. *World International Property Organization*, WO 99/57435 A1: 1-26. November 11.
- [8] Maalawi, K.Y. & Negm, H.M. (2002). “Optimal frequency design of wind turbine blades”. *Wind Engineering and Industrial Aerodynamics*, 90(8): 961-986. August.
- [9] Mckittrick, L.R., Cairns, D.S., Mandell, J., Combs, D.C., Rabem, D.A. & VanLuchene, R.D. (2001). “Analysis of a Composite Blade Design for the AOC 15/50 Wind Turbine using a Finite Element Model.” SAND2001-1441. *Sandia National Laboratories Contractor Report*. May 2001.
- [10] Zweben, C. (1989); “*Introduction to Mechanical Behavior and Properties of Composites Materials*”; DCDE, Volume 1.
- [11] Larsen, G.C., Hansen, M.H., Baumgart, A., Carlen, I. (2002). “Modal Analysis of Wind Turbine Blades”. Technical Report Risø-R-1181. *Risø National Laboratory*.
- [12] Sharma, R.N. & Madawala U.K. (2012). “The concept of a smart wind turbine system”. *Journal of Renewable energy*, 39(1): 403-410. September.

- [13] Imraan, M., Sharma, R.N. and Flay, R.G.J. (2010). "Wind tunnel testing of a wind turbine with telescopic blades: the influence of step change in chord". *17th Australian Fluid mechanics conference*. Auckland, New Zealand. December.

Authors

Lagoue TARTIBU KWANDA is a Congolese Engineer who is currently doing his Doctorate at Cape Peninsula university of Technology. He holds a Bachelor degree in Electromecanique from the University of Lubumbashi and a Master degree in mechanical engineering from Cape Peninsula University of technology.

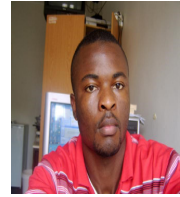

Mark Kilfoil, Pr Eng, Msc, Bsc, Bcom, HDET is a South African Professional Engineer with wide experience in mining equipments. He has previously worked at the University of Johannesburg and is currently working as lecturer in Mechanical Engineering at Cape Peninsula University of Technology.



Alna Van der Merwe, Ph D (University of Pretoria) is a South African applied mathematician. She was a senior lecturer first at the University of Pretoria until 2001, and then at the Cape Peninsula University of Technology. Currently she works at the Auckland University of Technology. Her research deals mainly with various aspects of linear vibration models.

